

ME863_03 (zu M2389)

Art. 7530 / 7533

DIN EN 1129-1/-2



D CH AT LI LU

Wichtige Hinweise

Das Aufstellen und Verankern sowie nachträgliche Einstellungen dieses Querklappbettes dürfen nur von hierfür geeigneten und geschulten Fachkräften ausgeführt werden.

Dieses Querklappbett muss auf einem standfesten Boden stehen. Unebenheiten müssen ausgeglichen werden, da das Bett waagrecht und lotrecht stehen muss.

Dieses Querklappbett ist vor dem Öffnen unbedingt mittels der beigegebenen Befestigungswinkel mit der Wand zu verankern. Je Befestigungswinkel sind 4 Schrauben zu verwenden. Die Tragfähigkeit der Wand muss hierbei gewährleistet sein.

Nur Befestigungsmittel aus dem Fachhandel verwenden die für die Gegebenheit der Wand ausgelegt sind.

Haltekraft: mind. 400 N (40 kg) je Befestigungswinkel!

Warnung vor fehlerhafter Montage.

Bei mangelnder Befestigung besteht Unfallgefahr!

Die eingebauten Beschläge sind wartungsfrei.

Die Beschläge sind für ein Matratzengewicht von 10 – 15 kg geeignet. Max. Matratzenhöhe 200mm.

Zum Öffnen und Schließen des Bettes ist der Griff zu benutzen: „Quetschgefahr!“

GB US

Important note

This wall folding bed may only be set up, anchored and subsequently adjusted by suitably trained professionals.

This wall folding bed must stand on firm ground. Uneven surfaces must be compensated, as the bed aligned both horizontally and perpendicularly.

Before opening this wall folding bed, it must be anchored to the wall using the enclosed fastening brackets. Each fastening bracket must be bolted with 4 screws. Make sure the load-bearing ability of the wall is sufficient.

Only use fasteners from specialist retailers that are designed for the specific wall.

Holding force: at least 400 N (40kg) per fastening bracket!

Beware of the dangers of incorrect assembly.

Risk of injury if inadequately fastened!

The incorporated hardware is maintenance-free.

The fittings are suitable for a mattress weighing 10-15 kg. Max. height of the mattress: 200 mm.

Use the handle to open and close the bed : risk of crushing.

FR BE NC

Remarques importantes

Uniquement des spécialistes compétents et dûment formés sont autorisés à installer, à ancrer et à régler ultérieurement ce lit escamotable transversal.

Ce lit escamotable transversal doit être posé sur un sol stable. Il faut compenser les inégalités, le lit devant être posé perpendiculairement et à l'horizontale.

Il est impératif d'ancrer ce lit escamotable transversal dans le mur avec les équerres de fixation fournies avec le lit. Utiliser 4 vis par équerre de fixation. Il doit être alors garanti que le mur est suffisamment porteur.

Utiliser uniquement des moyens de fixation de magasins spécialisés adaptés à la nature du mur. Force de maintien: min. 400N (40kg) par équerre de fixation!

Attention au montage incorrect.

Risque d'accident en cas d'un manque de fixation!

Les ferrures montées ne nécessitent aucun entretien.

Les ferrures sont compatibles avec un matelas pesant entre 10 et 15kg. Hauteur max. Du matelas 200mm.

Utiliser la poignée pour ouvrir et fermer le lit: «Risque d'écrasement»!

NL

Belangrijke aanwijzingen

Het plaatsen en verankeren evenals latere instellingen van dit opklapbed mogen alleen maar worden uitgevoerd door geschikt en geschoold vakpersoneel.

Dit opklapbed moet op een standveilige ondergrond staan. Oneffenheden moeten geëgaliseerd worden omdat het bed horizontaal en verticaal in het lood moet staan.

Dit opklapbed moet vóór het openen eerst met de bijgeleverde bevestigingshoeken aan de wand worden gemonteerd. Elke bevestigingshoeken moet met 4 schroeven bevestigd worden. Hierbij moet gewaarborgd zijn dat de wand over voldoende draagvermogen beschikt.

Gebruik uitsluitend in de vakhandel verkrijgbaar bevestigingsmateriaal dat berekend is op de hoedanigheid van de wand.

Draagvermogen minimaal 400 N (40kg) per bevestigingshoek!

Waarschuwing voor onjuiste montage

Bij onjuiste/gebrekkige bevestiging bestaat gevaar voor ongevallen!

De ingebouwde beslagen vergen geen onderhoud.

De beslagen zijn berekend op een matrasgewicht van 10-15 kg. Max. matrashoogte 200mm.

Gebruik de greep om het bed uit of op te klappen: 'Gevaar voor bekneeld raken'!

IT

Note importanti

Questo letto a scomparsa ribaltabile deve essere montato e fissato, nonché successivamente regolato, solo da personale specializzato e istruito in merito.

Il letto a scomparsa a ribalta orizzontale deve essere appoggiato su un fondo stabile. I dislivelli della superficie devono essere compensati, perché la posizione del letto deve essere orizzontale e a piombo.

Prima di essere aperto, questo letto a scomparsa ribaltabile deve essere fissato alla parete con gli angolari in dotazione. Per ogni angolare devono essere utilizzate 4 viti. Verificare che la capacità di carico della parete sia sufficiente.

Utilizzare solo elementi di fissaggio reperibili presso rivenditori specializzati e idonei alla struttura della parete.

Forza di tenuta: almeno 400 N (40 kg) per ogni angolare di fissaggio!

Attenzione ai montaggi scorretti.

Se il letto non viene fissato correttamente, sussiste il pericolo di infortuni!

Le garniture montate sono esenti da manutenzione.

Le garniture sono adatte a materassi con un peso di 10 – 15 kg. Altezza max. del materasso 200 mm.

Utilizzare la maniglia per aprire e chiudere il letto: "Pericolo di schiacciamento"!

SI

Pomembni napotki

Postavitvev in sidranje ter naknadne nastavitve te prečne zložljive postelje lahko opravijo samo za to ustrezno usposobljeni strokovnjaki.

Prečno zložljiva postelja mora stati na stabilnih tleh. Neravnosti je treba izravnati, ker mora postelja stati vodoravno.

Preden prečno zložljivo posteljo odprete, jo je treba s priloženim pritrdilnim kotnikom zasidrati v zid. Za vsak pritrdilni kotnik je treba uporabiti po 4 vijake. Nosilnost zidu mora biti ustrezna.

Uporabljajte samo pritrdilna sredstva iz specializirane trgovine, primerna za sestavo zidu.

Držalna sila: najm. 400 N (40 kg) na pritrdilni kotnik!

Opozorilo zaradi napačne montaže.

Pri pomanjkljivi pritrditvi obstaja nevarnost nesreč!

Vgrajenih okovov ni treba vzdrževati.

Okovi so primerni za težo vzmetnice od 10 do 15 kg. Najv. višina vzmetnice 200 mm.

Posteljo odprite in zaprite za ročaj: "Nevarnost zmečkanin!"

XS HR BA

Važne napomene

Postavljanje, pričvrščevanje i naknadno namještanje poprečno otklopivog kreveta smije obavljati samo stručnjak koji je odgovarajuće kvalificiran za te zadatke.

Ovaj poprečno otklopivi krevet mora stajati na stabilnoj podlozi. Neravnine se moraju izravnati jer krevet mora stajati vodoravno i okomito.

Ovaj poprečno otklopivi krevet prije otvaranja se mora pričvrstiti na zid pomoću priloženog pričvrstnog kutnika. Za svaki pričvrstni kutnik treba koristiti 4 vijka. Pritom zid mora imati dovoljnu nosivost.

Upotrijebite samo pričvrstnu opremu iz specijalizirane trgovine koja je predviđena za strukturu vašeg zida.

Pridržna sila: min. 400 N (40 kg) za svaki pričvrstni kutnik!

Upozorenje na pogrešnu montažu.

Kod nedovoljnog pričvršćenja postoji opasnost od nezgode!

Ugrađeni okovi ne moraju se održavati.

Okovi su predviđeni za težinu madraca od 10 do 15 kg. Maks. visina madraca 200 mm.

Za otvaranje i zatvaranje kreveta koristite ručku: „Opasnost od gnječenja!“

HU

Fontos útmutatások

A jelen oldalánál lenyitható ágynak a felállítását és lerögzítését, valamint utólagos beállítását csak erre alkalmas és megfelelő szakképzettséggel rendelkező szakemberek végezhetik el.

Az oldalánál lenyitható ágynak stabil padlózatón kell állnia. Az egyenetlenségeket ki kell egyenlíteni, mert az ágynak vízszintesen és merőlegesen kell állnia.

Az oldalánál lenyitható ágyat kinyitás előtt feltétlenül falhoz kell rögzíteni a mellékelt rögzítő szögvasak segítségével. Rögzítő szögvasanként 4 csavart kell használni. A fal teherbírásának megfelelőnek kell lennie.

Csak szakkereskedésből származó, a fal jellemzőire méretezett rögzítőeszközöket használjon.

Tartóerő: min. 400 N (40 kg) rögzítő szögvasanként!

Figyelmeztetés hibás szerelésre.

Nem megfelelő rögzítés esetén balesetveszély áll fenn!

A beépített vasalatok nem igényelnek karbantartást.

A vasalatok 10 - 15 kg súlyú matrachoz megfelelők. Max. matracmagasság 200 mm.

Az ágy kinyitásához és összecsukásához a fogantyút kell használni: „Összenyomódás veszélye!”

BG

Важни указания

Монтажът и анкеруването, както и допълнителни настройки на това напречно съгъваемо легло се допуска да се извършват само от подходящи за целта и обучени специалисти.

Това напречно съгъваемо легло трябва да се намира на здрав под. Неравностите трябва да се изравнят, тъй като леглото трябва да е водоравно и нивелирано.

Това напречно съгъваемо легло трябва преди отварянето, непременно да се анкерува към стената с приложение винкел за закрепване. За всеки винкел за закрепване трябва да се използват 4 винта. При това трябва да е гарантирана товароносимостта на стената.

Да се използват само крепителни материали от специализираната търговска мрежа, които са оразмерени за даденостите на стената.

Сила на захващане мин. 400 N (40 kg) за всеки винкел за закрепване!

Предупреждение за грешен монтаж.

При недостатъчно закрепване съществува опасност от злополука!

Монтираният обков е без поддръжка.

Обковът е подходящ за тегло на матрака от 10 – 15 kg. Макс. височина на матрака 200mm.

За разгъване и съгъване на леглото да се използва ръкохватката: "Опасност от премазване"!

CZ SK

Důležitá upozornění

Instalace a ukotvení, stejně jako následné nastavení této příčné sklopné postele smí provádět jen vhodný a vyškolený odborník.

Tato příčné sklopná postel musí stát na stabilní podlaze. Musí se vyrovnat nerovnosti, protože postel musí být svisle i vodorovně vyrovnaná.

Tato příčné sklopná postel se před vyklopením musí bezpodmínečně ukotvit ke stěně pomocí dodávaného upevňovacího úhelníku. Na každý upevňovací úhelník použijte 4 šrouby. Musí být zaručena nosnost stěny.

Používejte jen přípevňovací materiál z odborného obchodu, který je vhodný pro příslušnou stěnu.

Přidrzná síla: min. 400 N (40 kg) na jeden upevňovací úhelník!

Výstraha před chybnou montáží.

Při nedostatečném připevnění hrozí nebezpečí úrazu!

Integrovaná kování jsou bezúdržbová.

Kování jsou určena pro hmotnost matrace 10 – 15 kg. Max. výška matrace 200 mm.

Pro vyklápění a sklápění postele použijte rukojeť: „Nebezpečí zhmoždění!“

SE

Viktiga anvisningar

Uppställning och förankring samt inställning i efterhand av denna sidofällbara säng får endast göras av lämpliga och utbildade fackmän.

Den här sidofällbara sängen måste stå på ett stadigt golv. Ojämnheter måste utjämnas då sängen måste stå vågrätt och lodrätt.

Den här sidofällbara sängen måste absolut vara förankrad i väggen med medföljande fästvinkel före nedfällning. Till varje fästvinkel ska fyra skruvar användas. Kontrollera att väggens hållfasthet är tillräcklig.

Använd endast en fästordning från fackhandeln som är gjord för väggens konstruktion.

Hållfasthet: minst 400 N (40 kg) per fästvinkel!

Varning för felaktig montering.

Om fäste saknas finns risk för olycka!

De inbyggda beslagen kräver inget underhåll.

Beslagen är lämpliga för en madrassvikt på 10 – 15 kg. Max. madrasshöjd 200 mm.

Använd handtaget för att fäller ner och upp sängen: "Risk för klämskador!"

RU LV LT GE

Важная информация

Установку и крепление, а также последующую регулировку этой встраиваемой откидной кровати должны выполнять только квалифицированные, специально обученные для этого специалисты. Откидная кровать должна стоять на прочном полу. Любые неровности должны быть устранены, поскольку кровать должна стоять строго горизонтально и перпендикулярно.

Перед откидыванием обязательно прикрепить откидную кровать к стене с помощью входящих в комплект поставки крепежных уголков. На каждый крепежный уголок использовать по 4 винта. При этом должна быть гарантирована способность нести нагрузку.

Использовать только профессиональные крепежные материалы, рассчитанные на применение с конкретной стеной.

Сила сопротивления: не менее 400 Н (40 кг) на каждый крепежный уголок!

Предупреждение о ненадлежащем монтаже.

При недостаточном закреплении существует опасность несчастного случая!

Установленная фурнитура не требует обслуживания и ухода.

Фурнитура рассчитана на матрасы весом 10 – 15 кг. Макс. высота матраса 200 мм.

Для откидывания и складывания кровати использовать ручку: в противном случае существует опасность защемления.

GR CY

Σημαντικές υποδείξεις

Το στήσιμο και η στερέωση όπως και οι άλλες απαραίτητες ρυθμίσεις αυτού του πτυσσόμενου κρεβατιού τοίχου πρέπει να εκτελούνται από έμπειρο και ειδικά εκπαιδευμένο τεχνικό προσωπικό.

Το κρεβάτι αυτό πρέπει να τοποθετείται σε σταθερό δάπεδο. Οι ανωμαλίες του δαπέδου πρέπει να εξομαλύνονται, ώστε το κρεβάτι να βρίσκεται πάντα σε οριζόντια και κατακόρυφη θέση.

Αυτό το πτυσσόμενο κρεβάτι τοίχου πρέπει πριν το άνοιγμα να στερεώνεται απαραίτητως στον τοίχο με τις παρεχόμενες γωνίες στερέωσης. Ανά γωνία στερέωσης πρέπει να χρησιμοποιούνται από 4 βίδες. Η φέρουσα ικανότητα του τοίχου πρέπει να είναι εξασφαλισμένη.

Χρησιμοποιείτε μόνο στερεωτικά του εμπορίου, κατάλληλα για το συγκεκριμένο είδος τοίχου.

Συγκρατούμενο φορτίο: ελάχ. 400 N (40 kg) ανά γωνία στερέωσης!

Προειδοποίηση εσφαλμένης συναρμολόγησης.

Σε περίπτωση ελαττωματικής στερέωσης μπορεί να προκληθεί ατύχημα!

Τα ενσωματωμένα σιδηρικά δεν χρειάζονται συντήρηση.

Τα σιδηρικά είναι κατάλληλα για ένα βάρος στρώματος 10 – 15 kg. Μεγ. ύψος στρώματος 200mm.

Για το άνοιγμα και κλείσιμο του κρεβατιού χρησιμοποιείτε τη λαβή: „Κίνδυνος σύνθλιψης!“

МК

Важни упатства

Поставувањето, прицврстувањето и дополнителното приспособување на овој кревет со странично склопување се изведува само од страна на соодветен и обучен стручен персонал.

Овој кревет со странично склопување мора да стои на стабилен под. Сите нерамнини мора да се израмнат, бидејќи креветот мора да стои хоризонтално и вертикално.

Пред да се отвори, креветот со странично склопување мора да се прицврсти на ѕидот со помош на доставениот држач за прицврстување. За секој држач за прицврстување се користат 4 завртки. За таа цел мора да се овозможи носивост на ѕидот.

Да се користат само средства за прицврстување од специјализирани продавници, кои се наменети за карактеристиките на ѕидот.

Сила на држење: најмалку 400 N (40 kg) по држач за прицврстување!

Предупредување за погрешна монтажа.

Постои опасност од несреќа во случај на несоодветно прицврстување!

Вградениот оков не треба да се одржува.

Оковот е наменет за тежина на душекот од 10 до 15 kg. Макс. висина на душек 200 mm.

За отворање и затворање на креветот се користи рачката: „Опасност од смачкување!“

PL

Ważne wskazówki

Ustawienie i zakotwiczenie oraz późniejsze regulacje składanego łóżka mogą być wykonywane tylko przez odpowiednich i przeszkolonych specjalistów.

Łóżko składane musi stać na stabilnym podłożu. Należy zniwelować nierówności, ponieważ łóżko musi stać poziomo i pionowo.

Przed otwarciem należy koniecznie zakotwiczyć łóżko w ścianie za pomocą dołączonych kątowników mocujących. Do każdego kątownika mocującego zastosować 4 śruby. Musi być zagwarantowana przy tym nośność ściany.

Używać tylko specjalistycznych elementów mocujących, odpowiednich do właściwości ściany.

Siła przytrzymująca: przynajmniej 400 N (40 kg) na kątownik mocujący!

Ostrzeżenie przed nieprawidłowym montażem.

W przypadku nieodpowiedniego zamocowania istnieje niebezpieczeństwo wypadku!

Wbudowane okucia nie wymagają konserwacji.

Okucia są przeznaczone do ciężaru materaca 10–15 kg. Maks. wysokość materaca 200 mm.

Do otwierania i zamykania łóżka używać uchwytu: „niebezpieczeństwo zmiążdżenia!”

TR

Önemli Bilgiler

Bu yandan katlanabilir yatağın kurulumu, sabitlemesi ve de sonradan ayarlanması sadece bu işler için uygun ve eğitilmiş olan uzman kişiler tarafından yapılmalıdır.

Bu yandan katlanabilir yatağın dayanıklı sarsılmaz bir zemin üzerine konulması gerekir.

Yatağın yatay ve dikey konumlarda durması gerektiğinden engebelerin düzlenmesi gerekir.

Bu yandan katlanabilir yatağın açılmadan önce mutlaka teslimat kapsamında bulunan tespit köşebentler ile duvarda sabitlemesi gerekir.

Her bir köşebent için 4 adet vida kullanılması gerekir.

Duvarın taşıma gücünün sağlanmış olması gerekir.

Sadece yetkili satıcıların, duvarın durumuna uygun sabitleme malzemelerini kullanınız.

Tutma gücü: Her bir köşebent için min. 400 N (40 kg)

Eksik montaja dair uyarı

Yetersiz sabitlemede kaza tehlikesi bulunmaktadır.

İç donanımlar bakım gerektiriyor

Bu donanımlar 10 - 15 kg ağırlığında döşekler için uygundur.

Maks. döşek yüksekliği 200 mm.

Yatağın açılıp kapanması için tutma kolunun kullanılması gerekiyor:

„Sıkıştırma Tehlikesi!“

DK

Vigtigt

Opstilling, fastgørelse og efterfølgende indstillinger af denne klapseng må kun foretages af fagfolk med passende træning.

Klapsengen skal stå på et stabilt underlag.

Ujævnheder skal udlignes, da sengen skal stå vandret og lodret.

Klapsengen skal altid forankres i væggen med de medfølgende fastgørelsesvinkler, før den åbnes.

Der skal bruges 4 skruer til hver fastgørelsesvinkel.

Det skal sikres, at væggen er tilstrækkeligt solid.

Brug kun fastgørelsesmidler fra en faghandel, som er beregnet til vægforholdene.

Hver vinkel skal kunne bære mindst 400 N (40 kg)!

Advarsel mod forkert montering

Manglende fastgørelse indebærer risiko for tilskadekomst!

De indbyggede beslag er vedligeholdelsesfri.

Beslagene er beregnet til en madrassvægt på 10-15 kg.

Maks. madrashøjde: 200 mm.

Sengen skal åbnes og lukkes ved hjælp af grebet.

"Klemningsfare!"

RO

Indicații importante

Amplasarea și ancorarea precum și reglajele ulterioare ale patului rabatabil transversal sunt permise numai persoanelor instruite adecvate și specializate în acest sens.

Acest pat rabatabil transversal trebuie să stea pe o podea stabilă. Neregularitățile trebuie egalizate pentru că patul trebuie să stea în plan orizontal și vertical.

Acest pat rabatabil transversal trebuie ancorat neapărat înainte de deschidere cu ajutorul cornierelor de fixare atașate. Utilizați pentru fiecare cornier de fixare câte 4 șuruburi. Capacitatea portantă a peretelui trebuie să fie asigurată.

Utilizați numai mijloace de fixare din magazinele specializate care sunt prevăzute pentru situația momentană a peretelui.

Forță de susținere: min. 400 N (40 kg) per cornier de fixare!

Avertizare în privința montajului eronat.

La o fixare insuficientă există pericol de accidentare!

Balamalele montate nu necesită întreținere.

Balamalele sunt adecvate pentru o greutate a salteii de 10 - 15 kg. Înălțime max. saltea 200mm.

Pentru deschiderea și închiderea patului utilizați mânerul: „Pericol de strivire!”

ES

Indicaciones importantes

La instalación y el anclaje de esta cama abatible horizontal, así como los posteriores trabajos de ajuste, serán realizados exclusivamente por personal técnico especializado y debidamente formado para ello.

Esta cama abatible horizontal deberá posicionarse sobre un suelo resistente. Las irregularidades deben ser compensadas, dado que la cama deberá sustentarse correctamente tanto horizontal como perpendicularmente.

Antes de poder abrir la cama abatible horizontal es preciso anclarla a la pared, utilizando las escuadras de fijación suministradas. Utilizar 4 tornillos para cada escuadra de fijación. Para ello, es importante asegurarse previamente de que la capacidad portante de la pared será suficiente.

Utilizar únicamente medios de fijación procedentes de comercios especializados y diseñados específicamente para el tipo de pared correspondiente.

¡Fuerza de sujeción: mín. 400 N (40 kg) por cada escuadra de fijación!

Advertencia en caso de montaje defectuoso.

¡Riesgo de accidente en caso de fijación inadecuada!

Los herrajes integrados no precisan mantenimiento.

Los herrajes son adecuados para un colchón de entre 10 y 15 kg. Altura máxima de colchón 200 mm.

Utilizar el tirador para abrir y cerrar la cama: "¡Riesgo de aplastamiento!"

PT

Indicações importantes

A instalação e a fixação, assim como os ajustes posteriores desta cama rebatível transversal, só podem ser realizados por profissionais devidamente aptos e qualificados para o efeito.

Esta cama rebatível transversal tem de estar instalada sobre um pavimento estável. É preciso compensar irregularidades, uma vez que a cama se tem de encontrar numa posição horizontal e perpendicular.

Antes de ser aberta, esta cama rebatível transversal tem de ser fixada sem falta à parede com os ângulos de fixação. Em cada ângulo de fixação são usados 4 parafusos. A capacidade de carga da parede tem de estar garantida para isso.

Use exclusivamente meios de fixação do comércio especializado que estejam concebidos para as condições da parede.

Força de suporte: no mín. 400 N (40 kg) por cada ângulo de fixação!

Aviso de risco devido a montagem errada.

Uma fixação incorreta leva a perigo de acidente!

As ferragens incorporadas não precisam de manutenção.

As ferragens são adequadas para um peso de colchão de 10 a 15 kg. Altura máx. do colchão 200 mm.

Use o manípulo para abrir e fechar a cama: "Perigo de esmagamento!"

1.

M2390_01

rauch

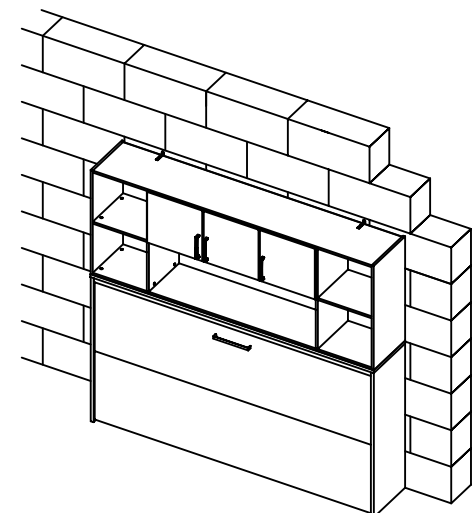
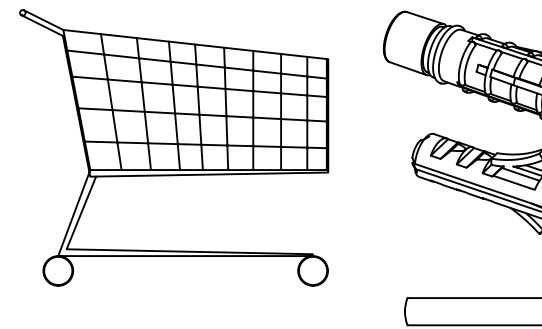
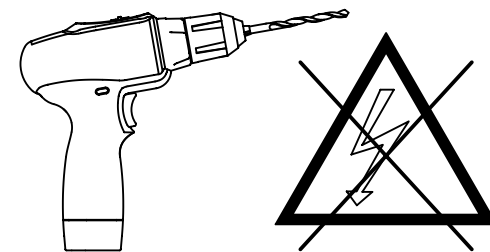
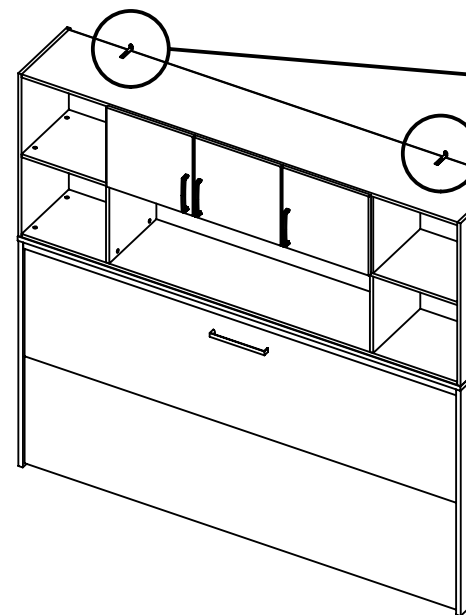
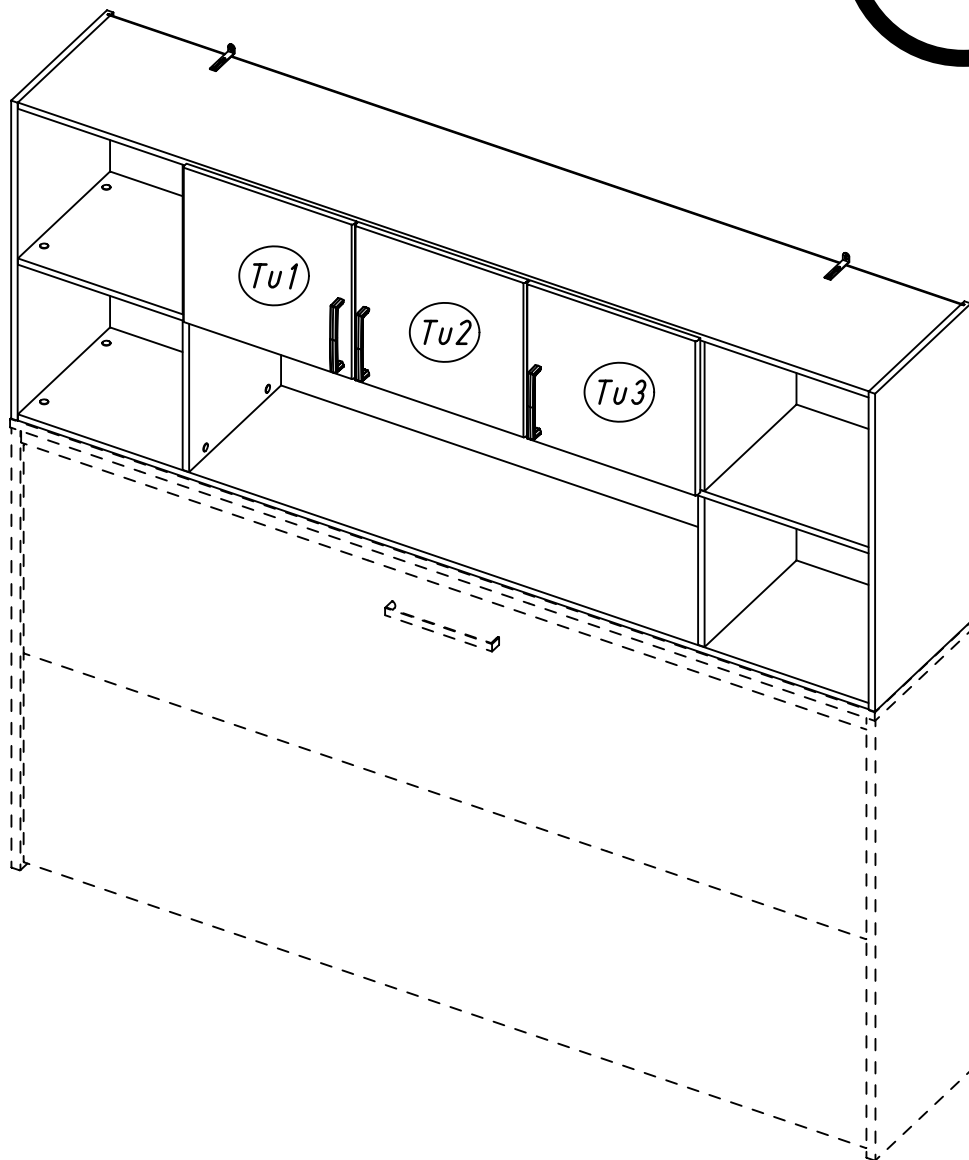
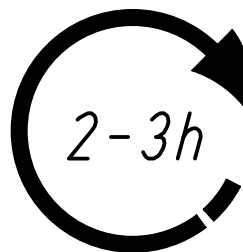
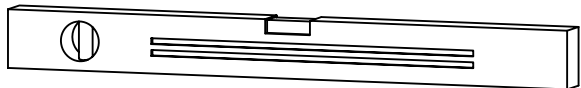
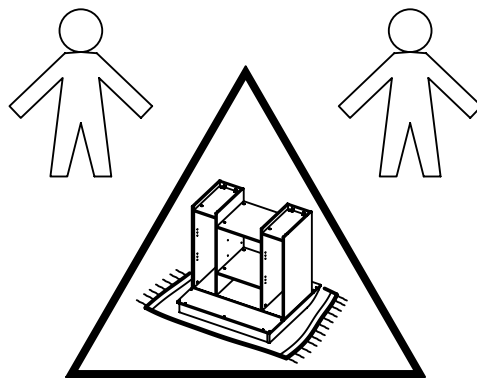
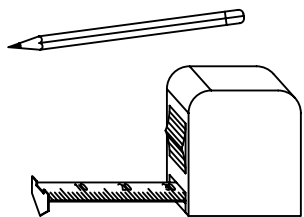
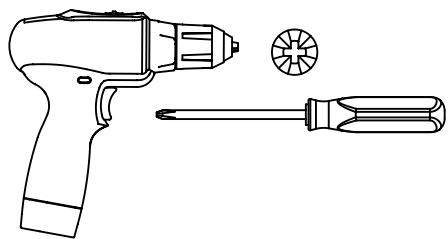

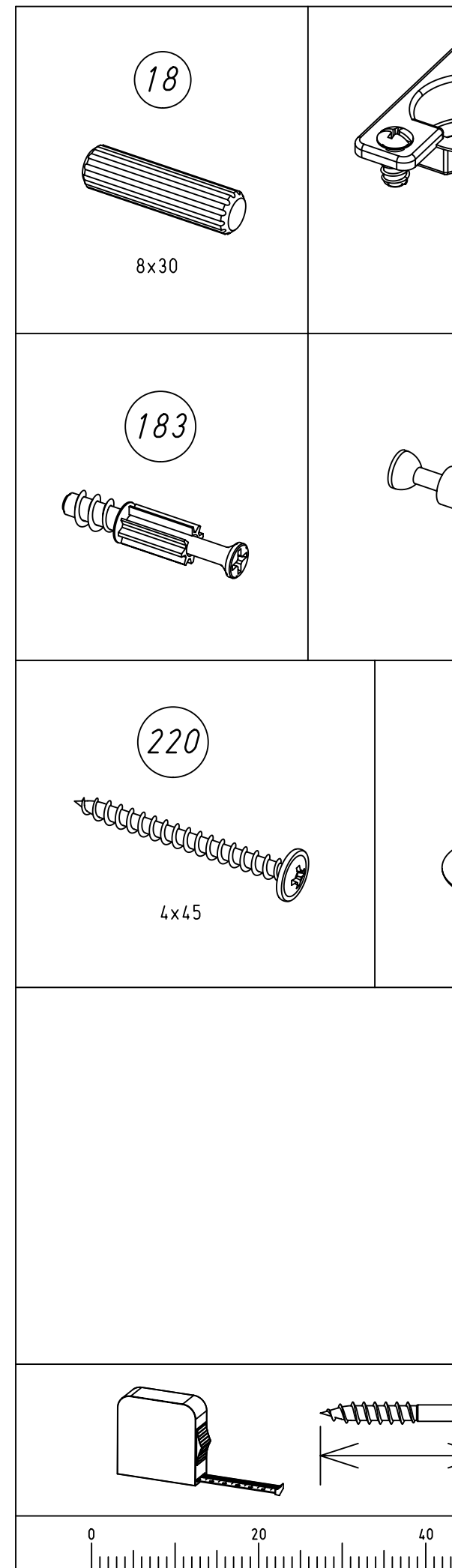
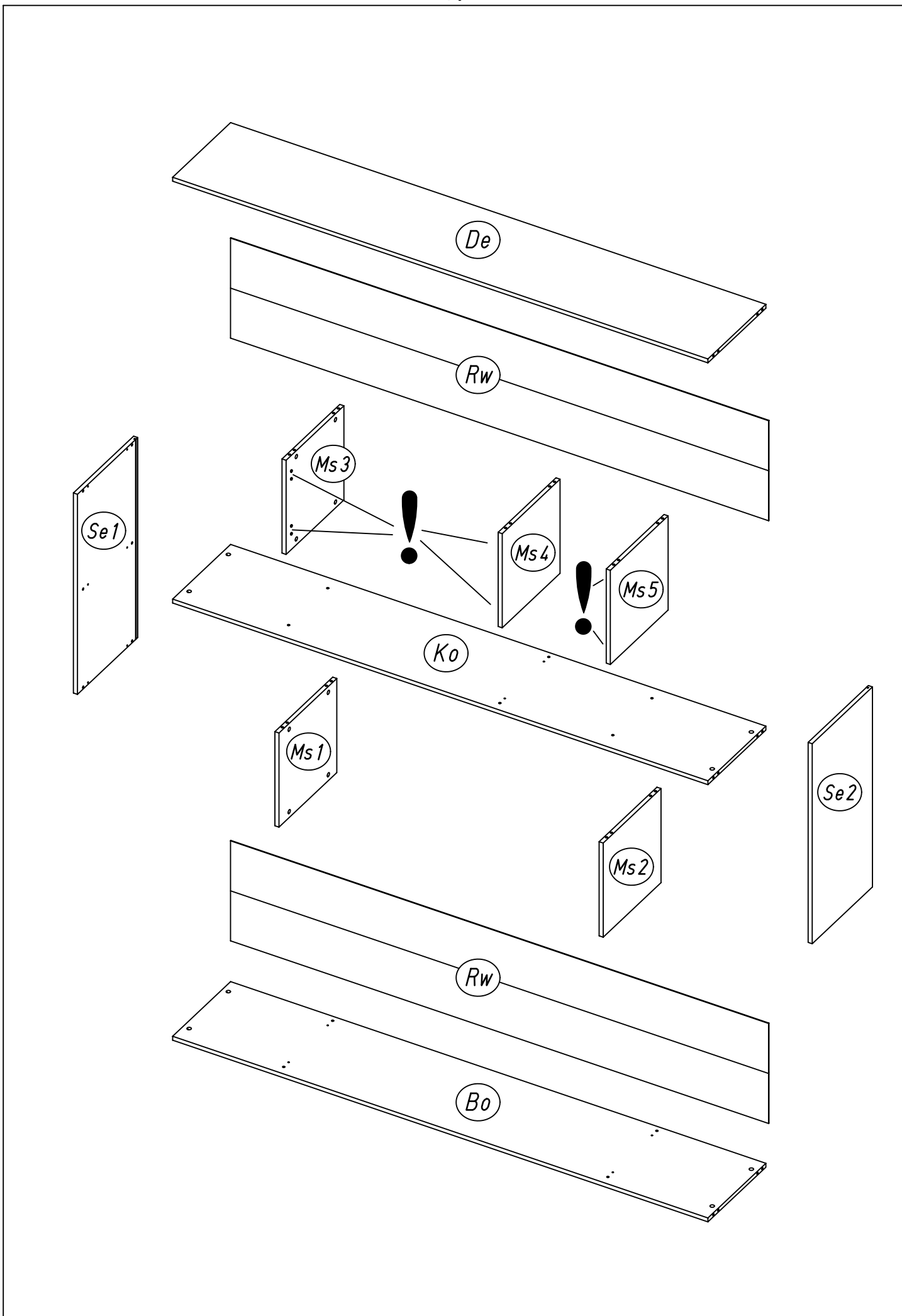

1

4x 18

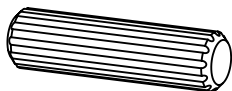

8x30

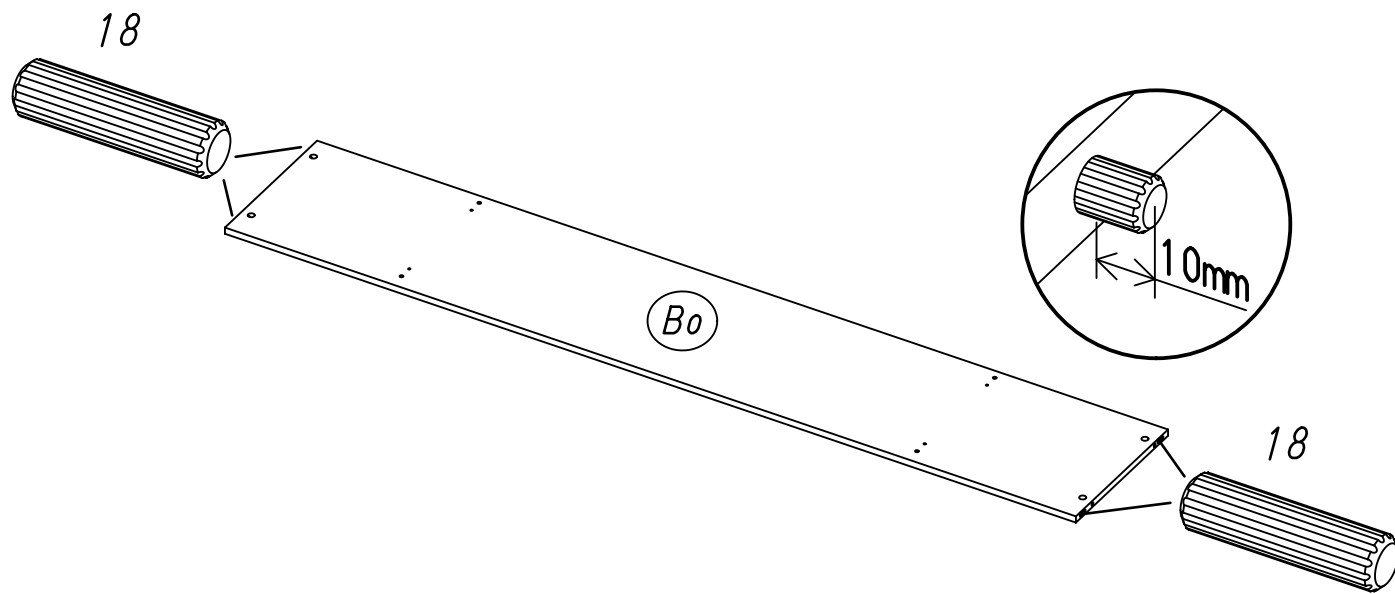

2

4x 173

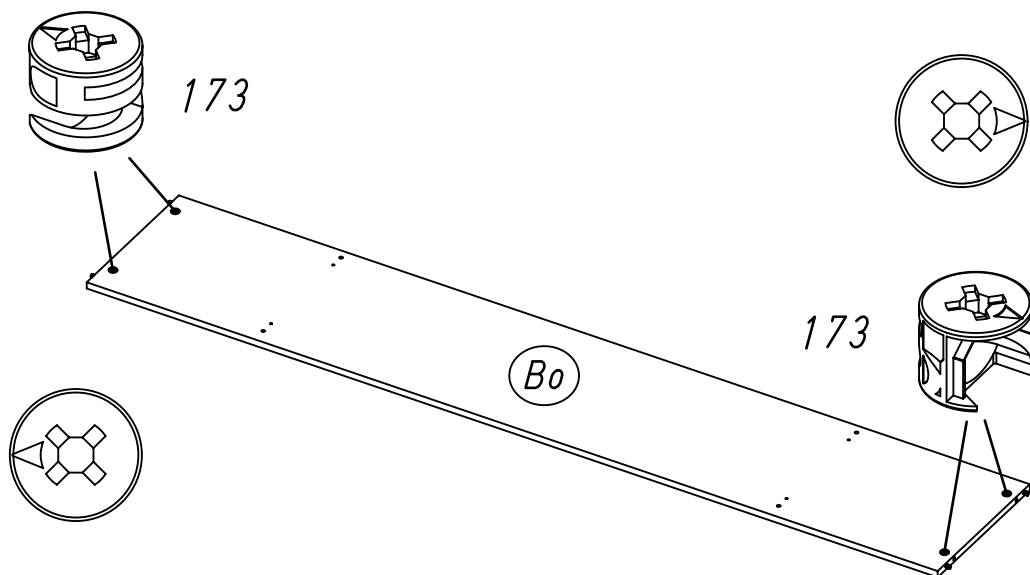
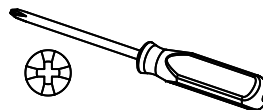
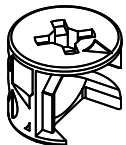

3

4x 183

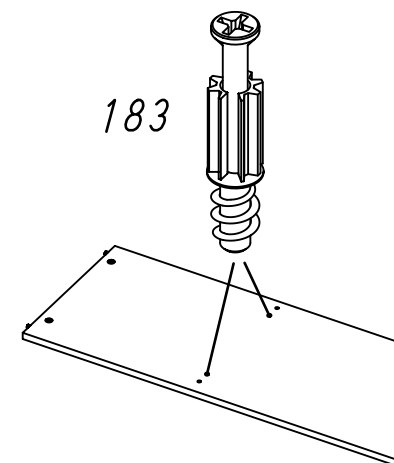
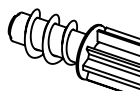

4

4x 18



8x30

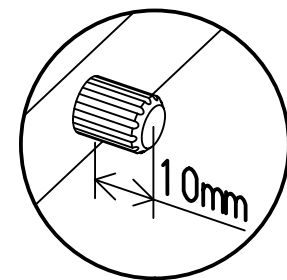

18

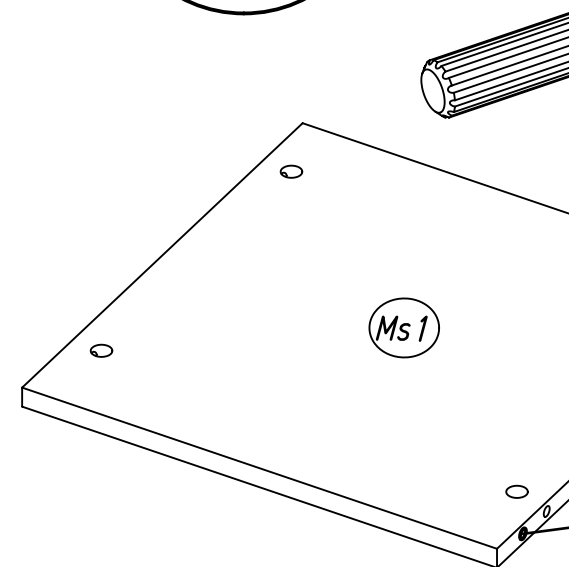

5

8x

173

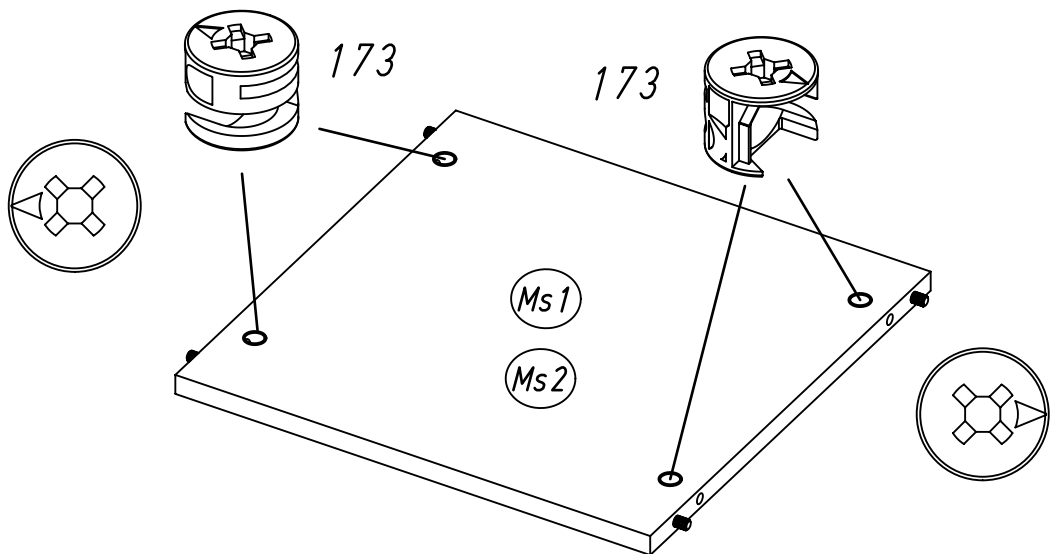
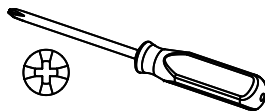
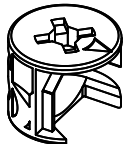

6

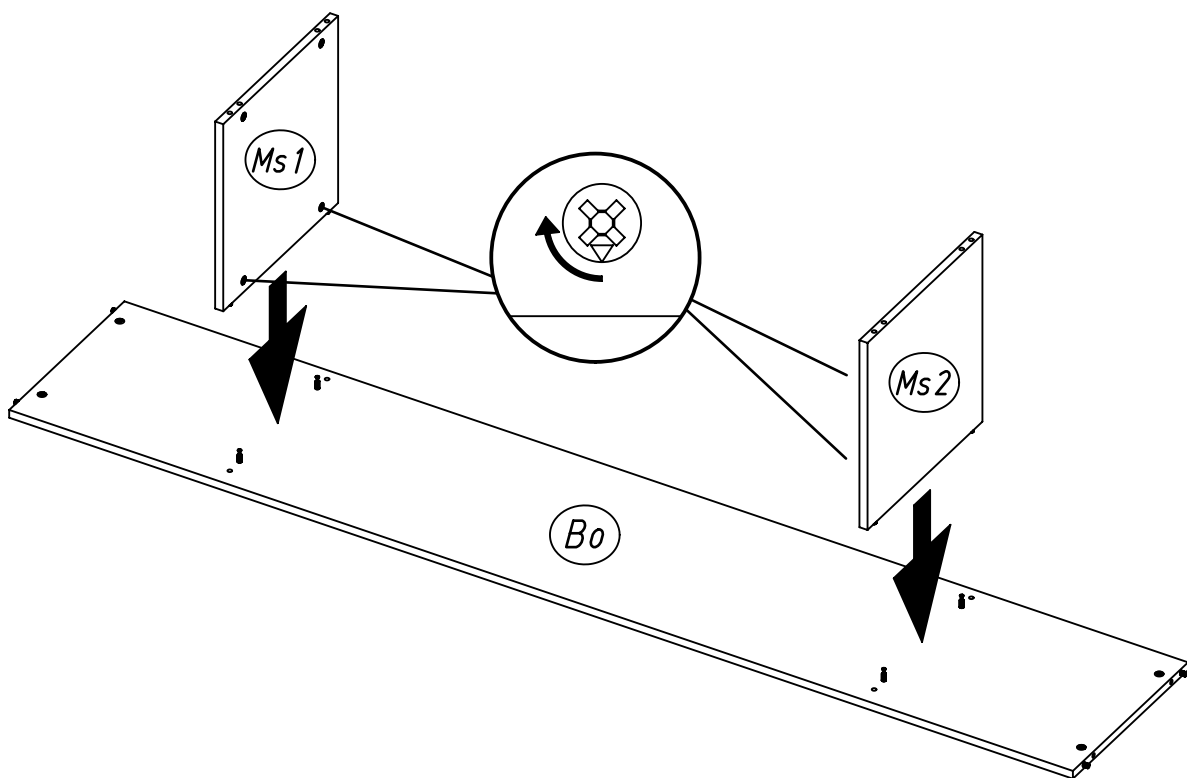
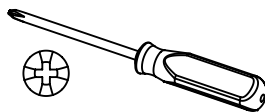

7

4x

18

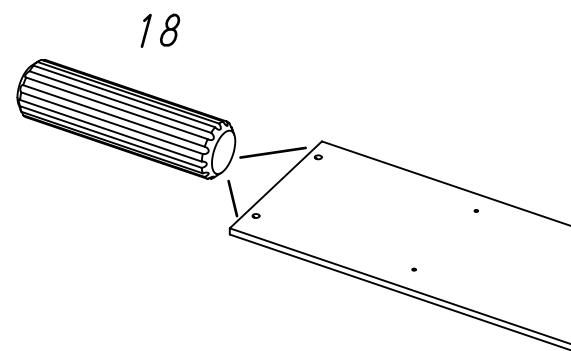
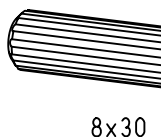

8

4x

173

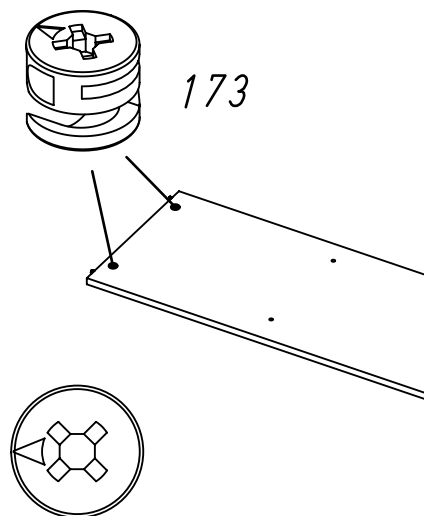

9.

9

4x 196



64/24x7

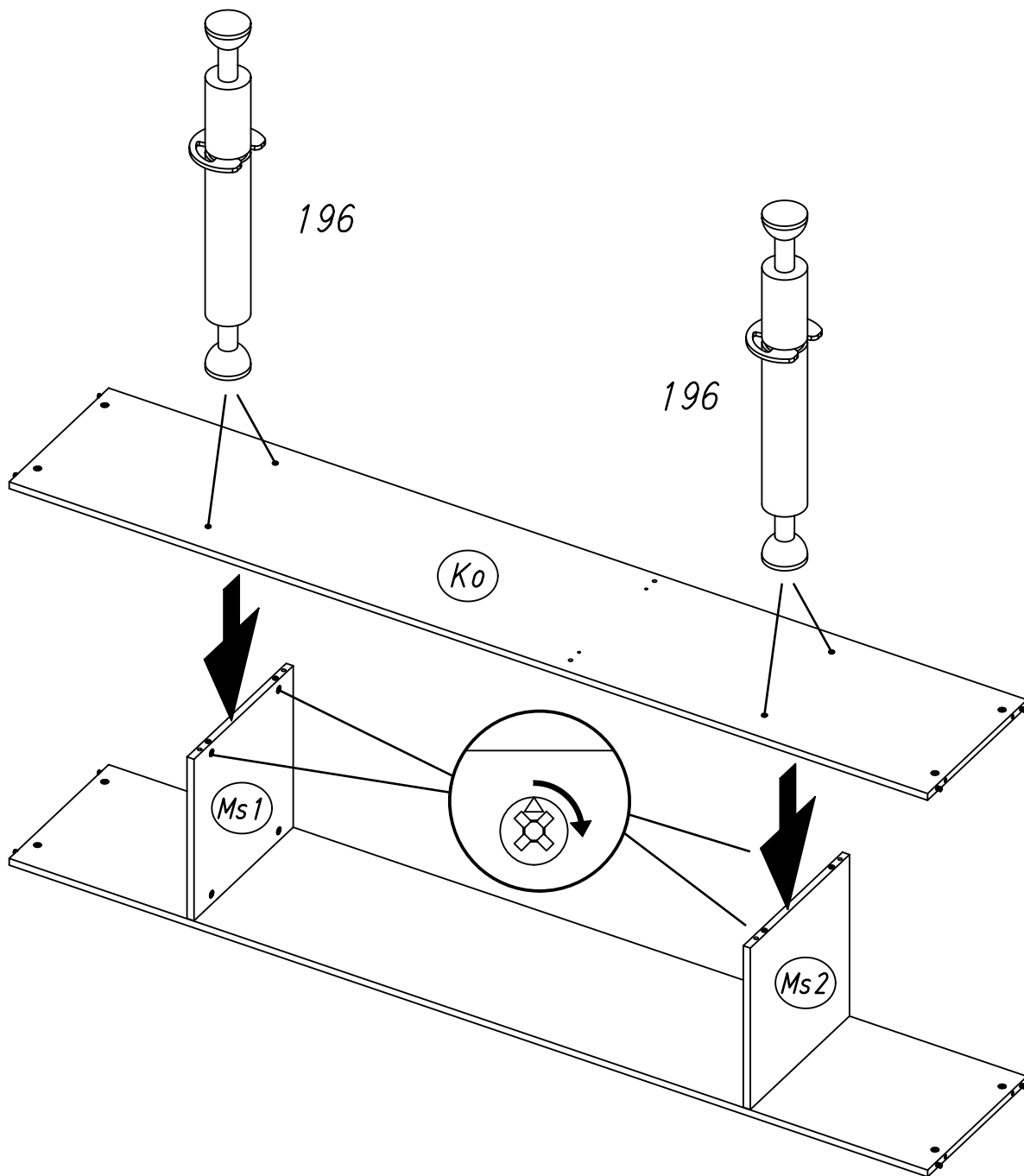
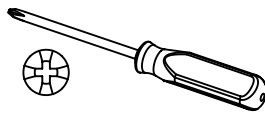

10

2x 183

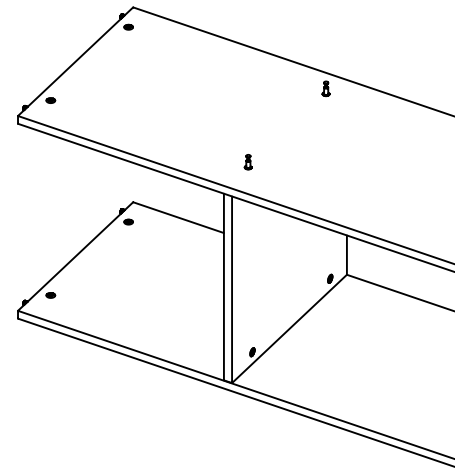
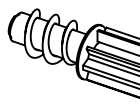

11

4x 18



8x30

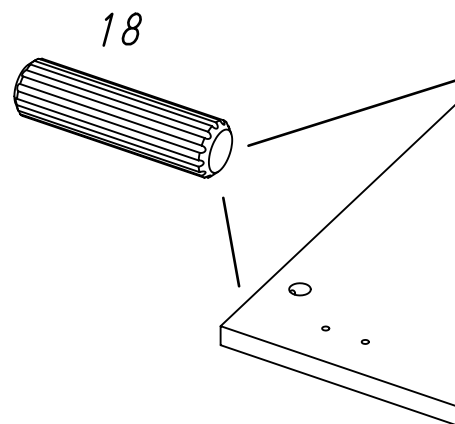

12

4x

173

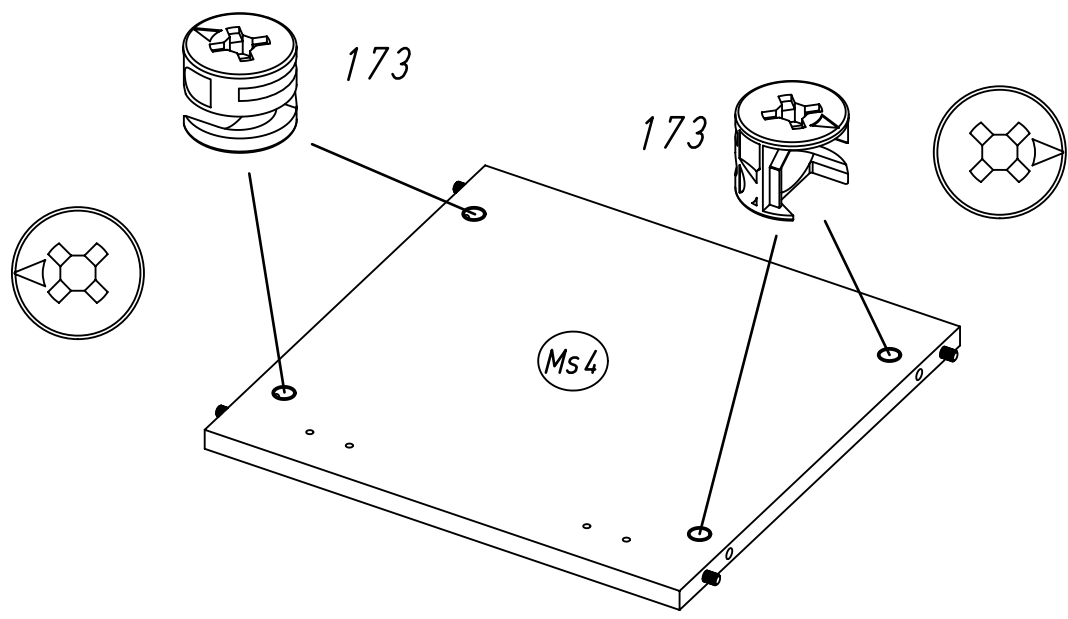
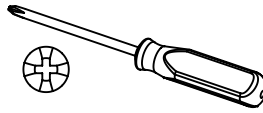

13

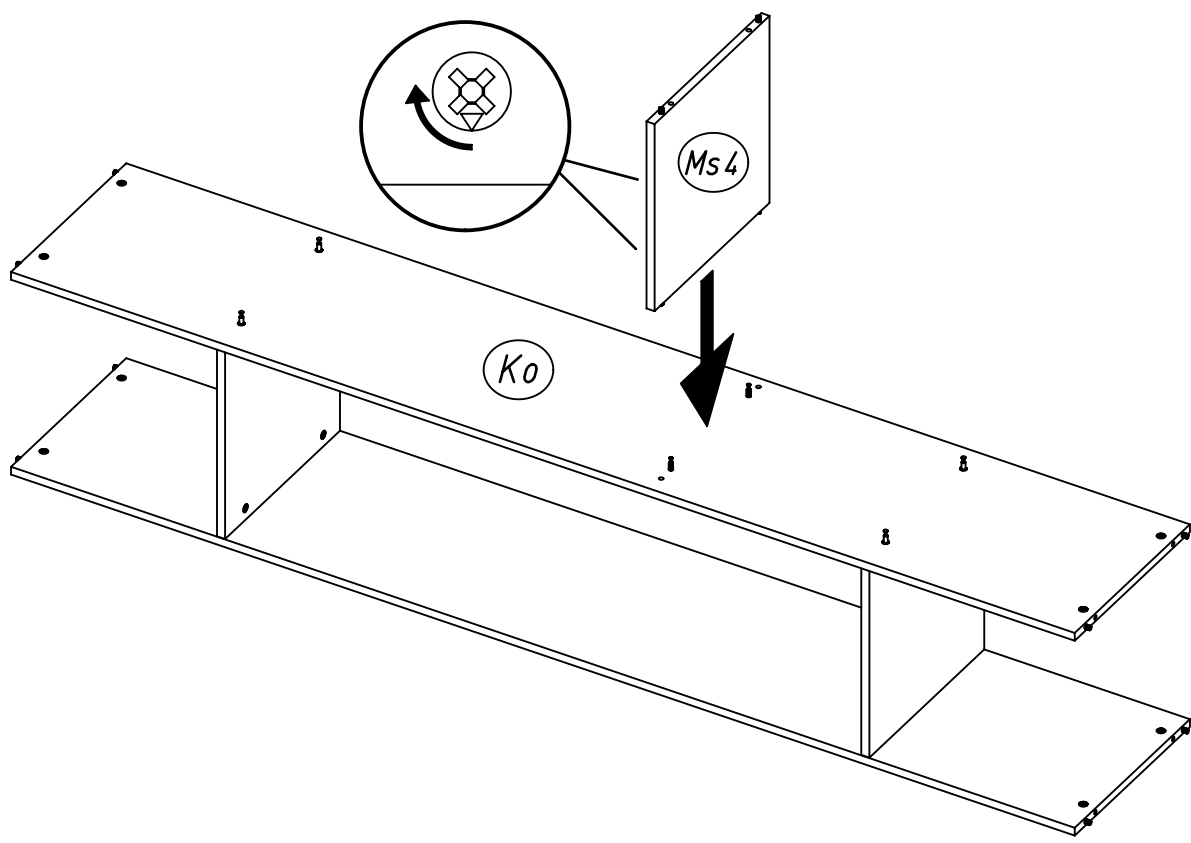
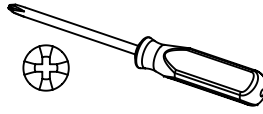

14

4x

18

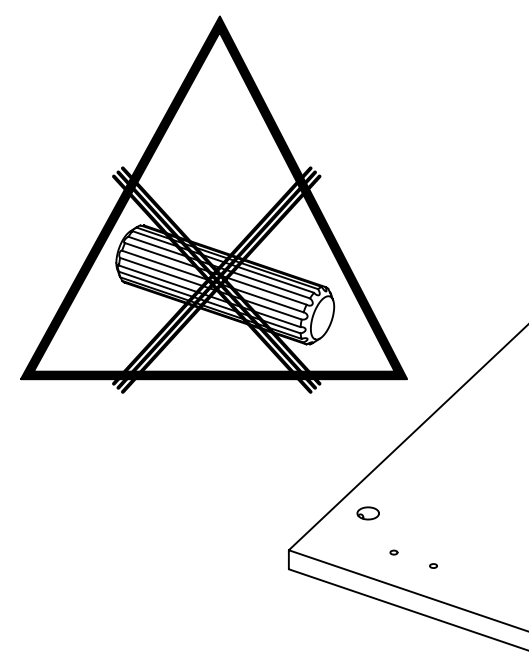
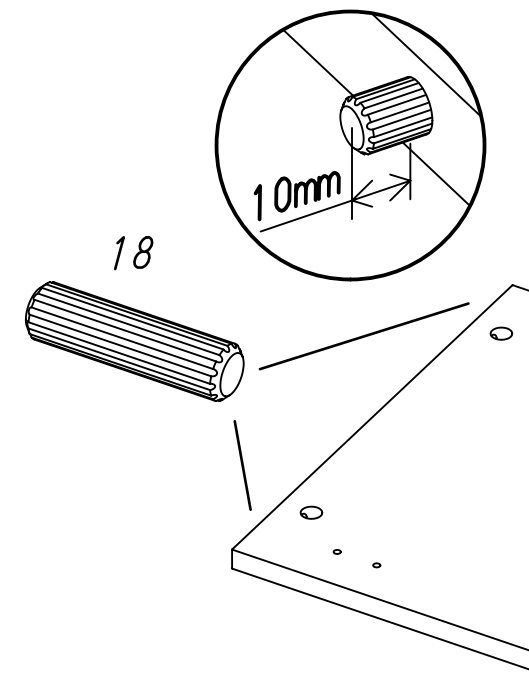
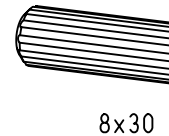

15

8x

173

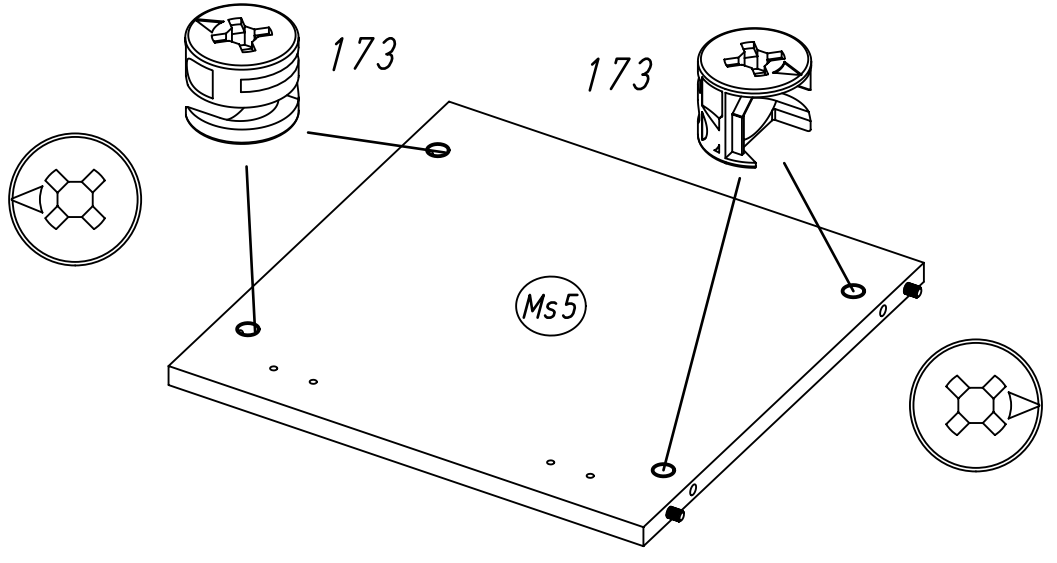
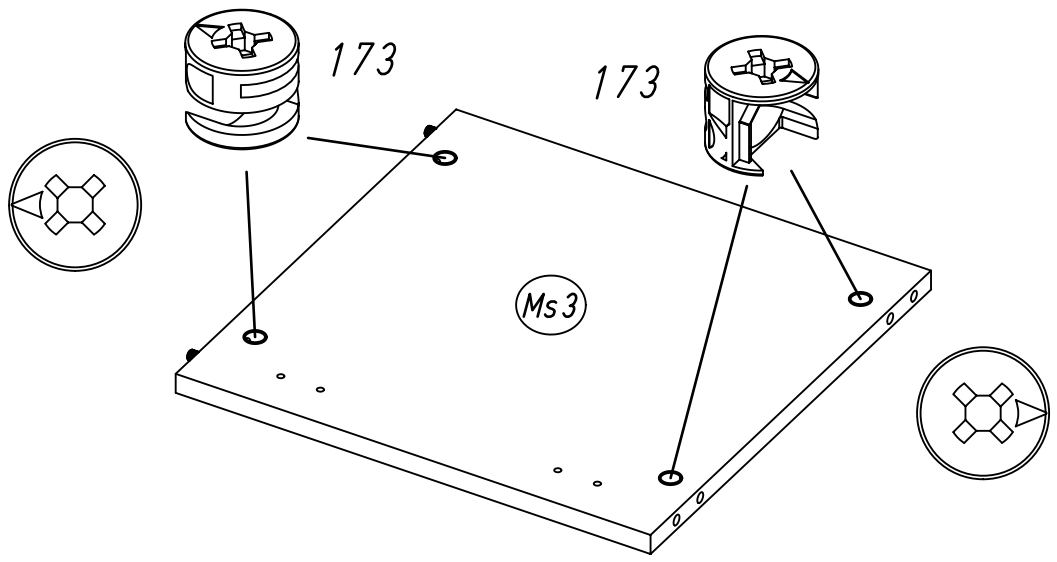
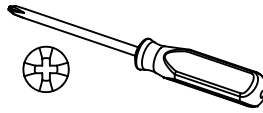

16

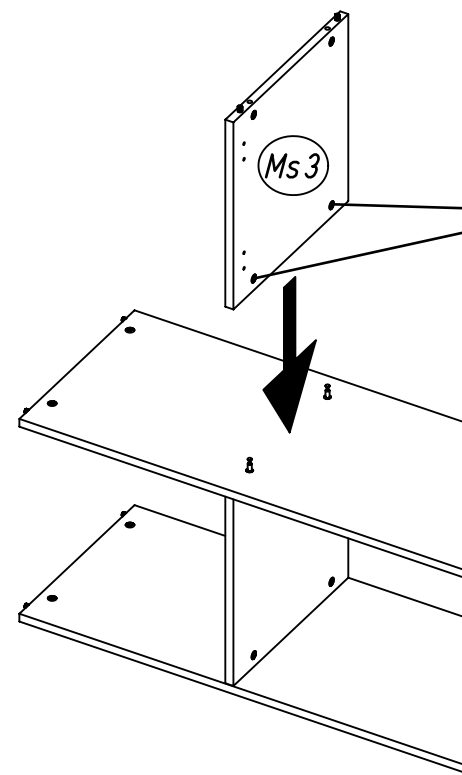

17

4x

18

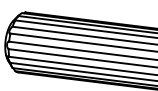

8x30

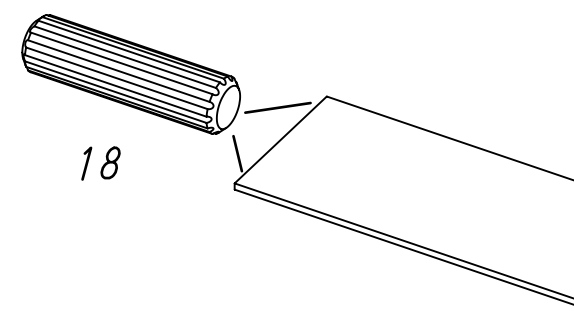

18

4x

173

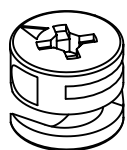
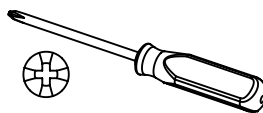
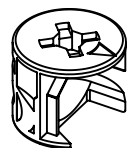

173

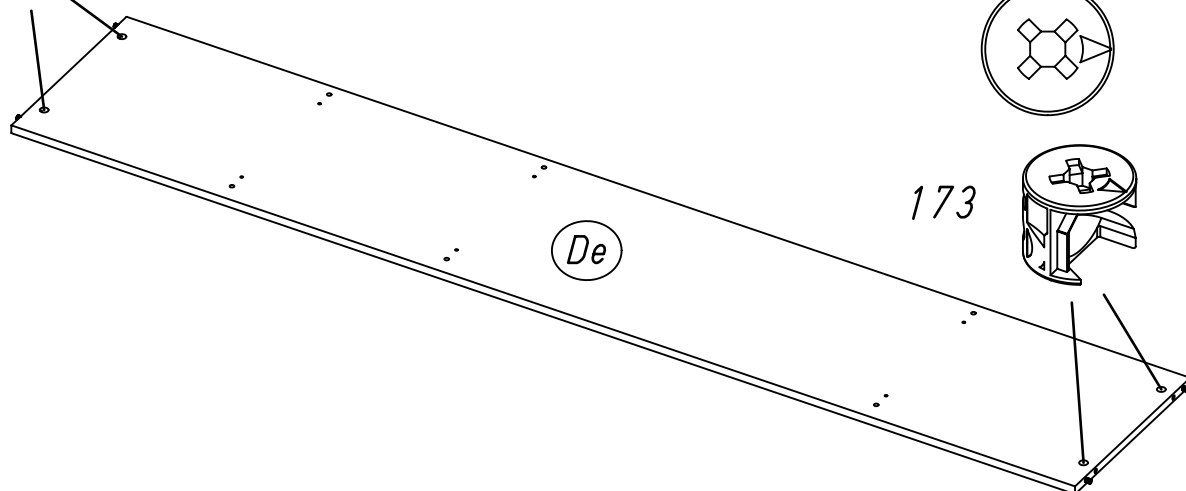
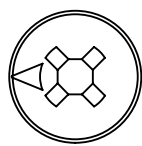

173

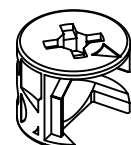
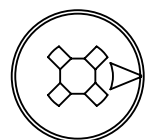

19

6x

183

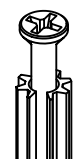
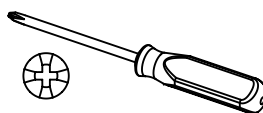
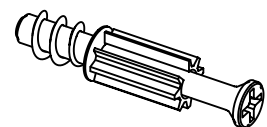

183

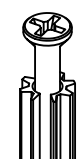

183

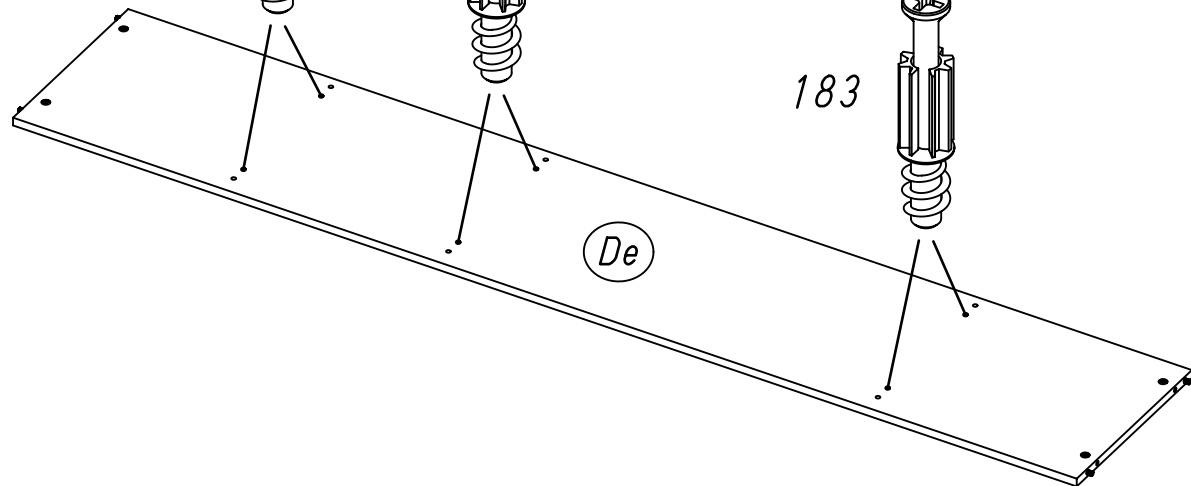
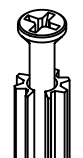

De

20

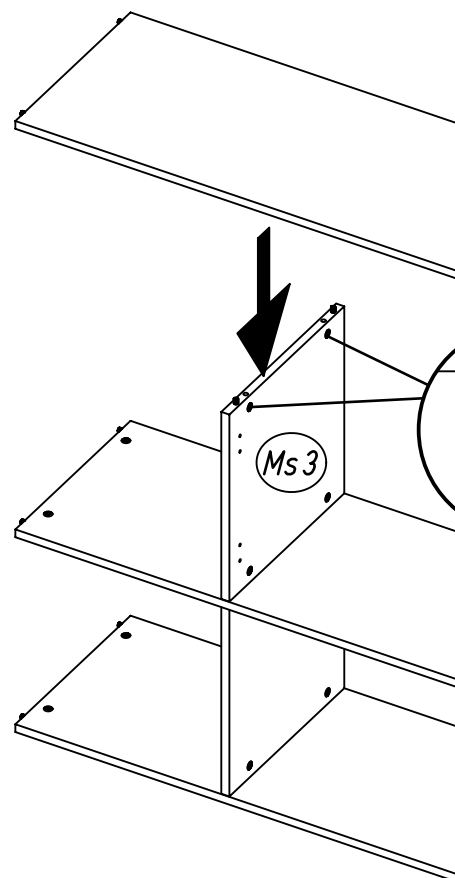

Ms3

21

12x

183

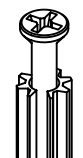

183

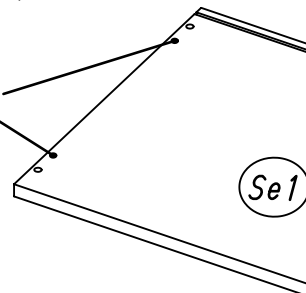

Se1

22

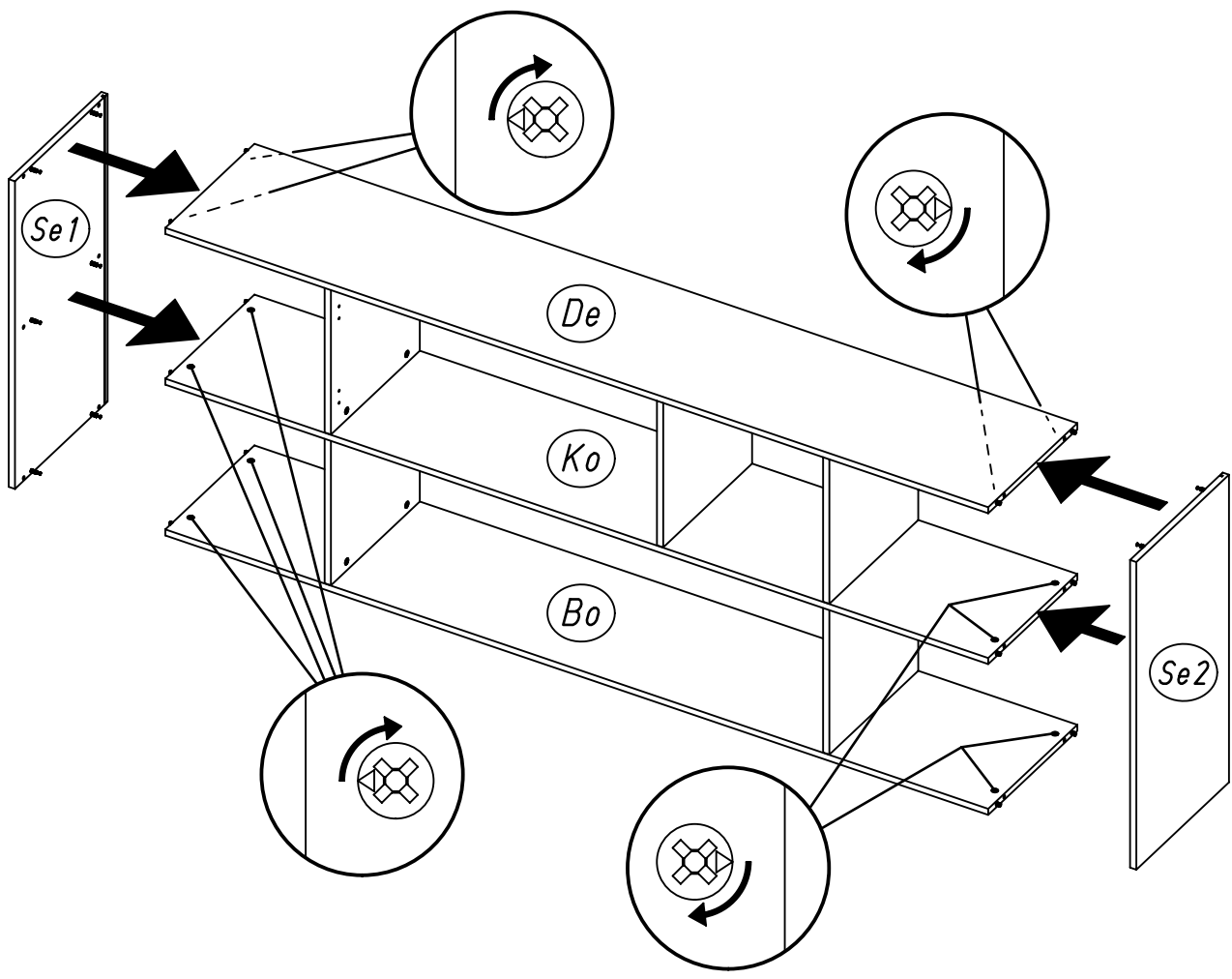
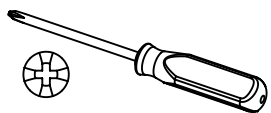

23

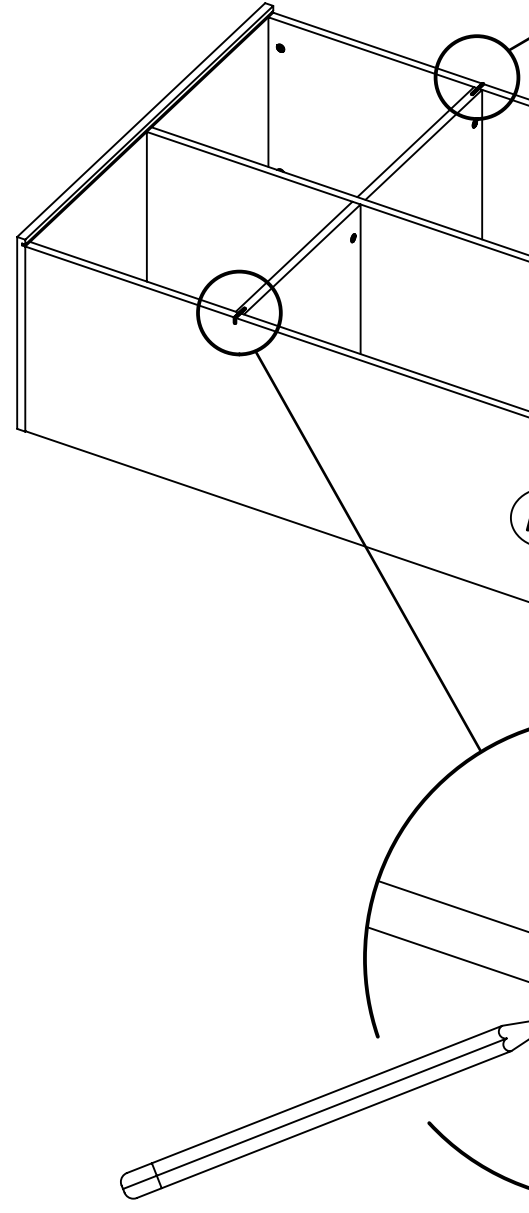

24

10x

215

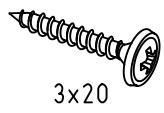

3x20

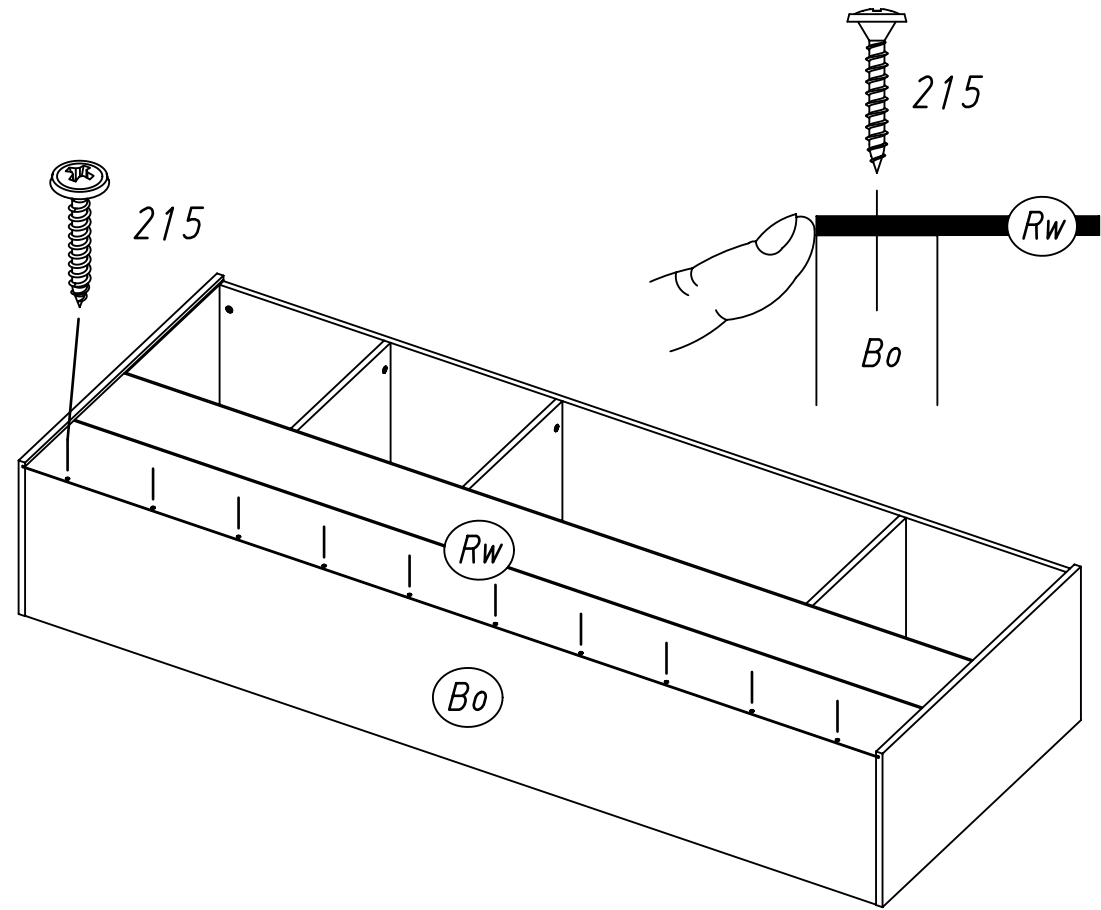
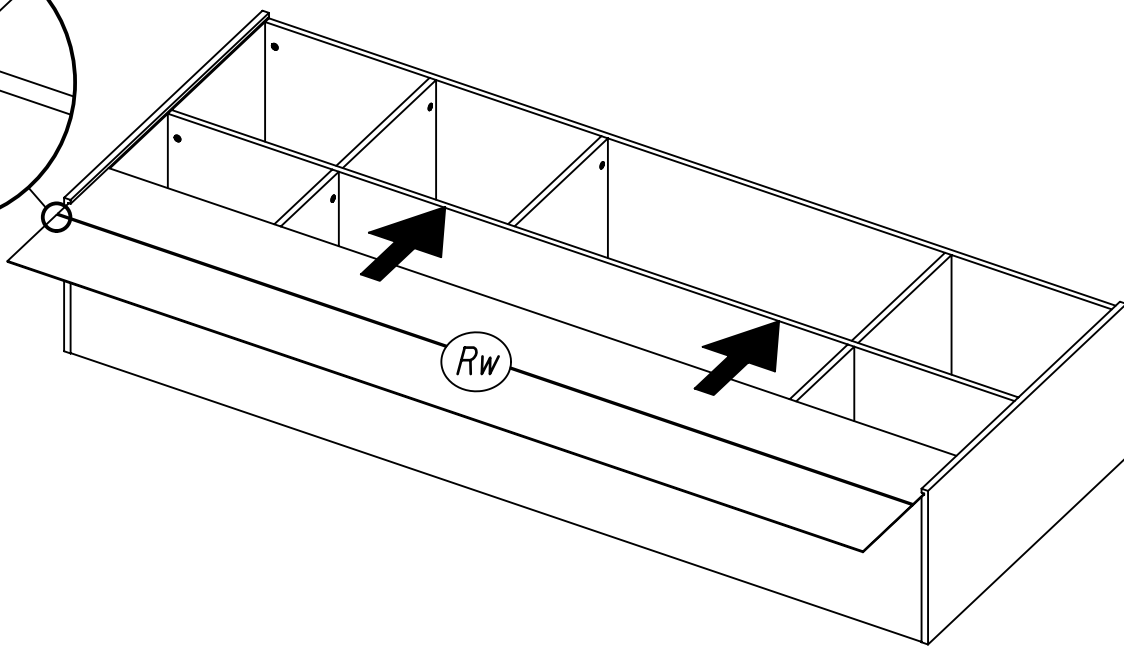
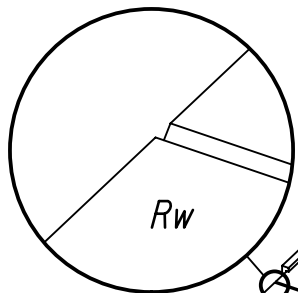
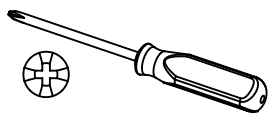

25

10x

215

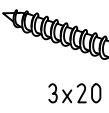

3x20

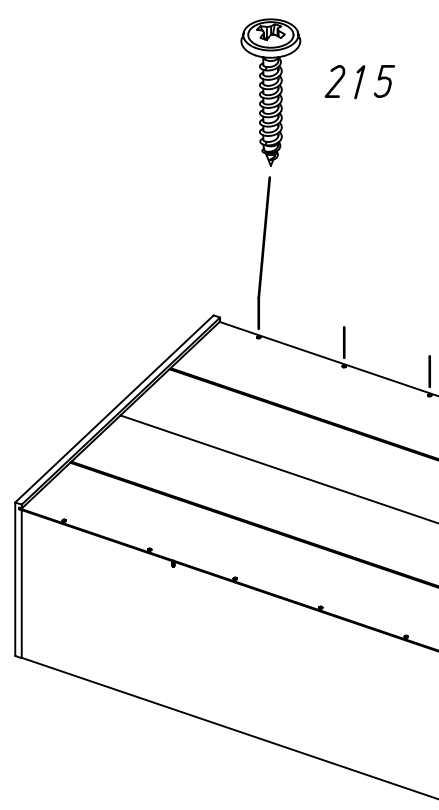
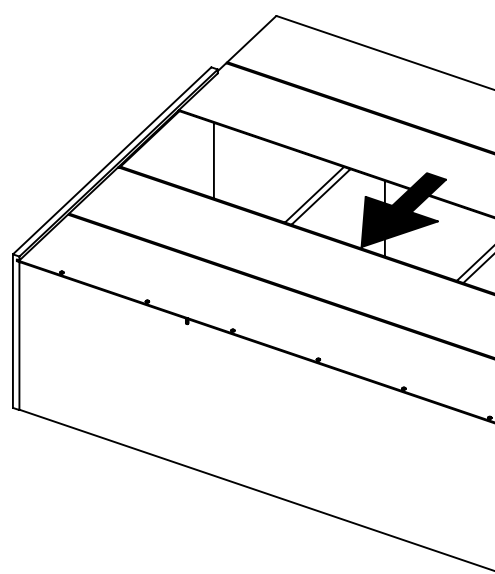

26

10x

215

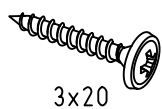

3x20

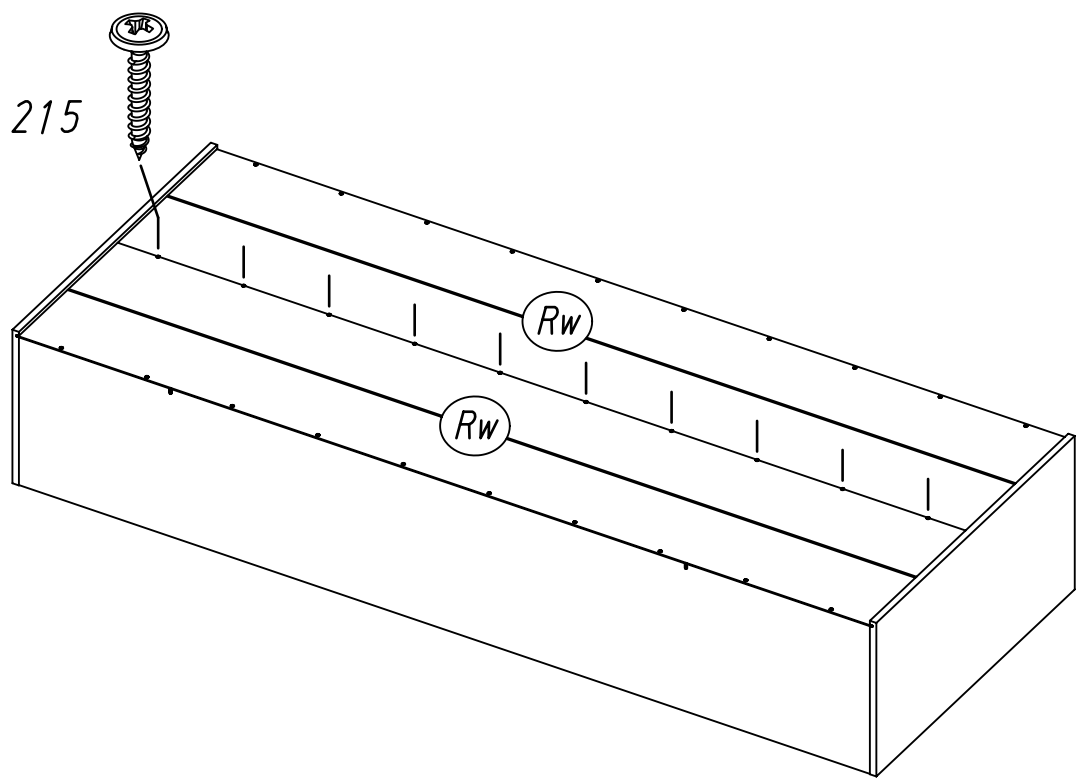
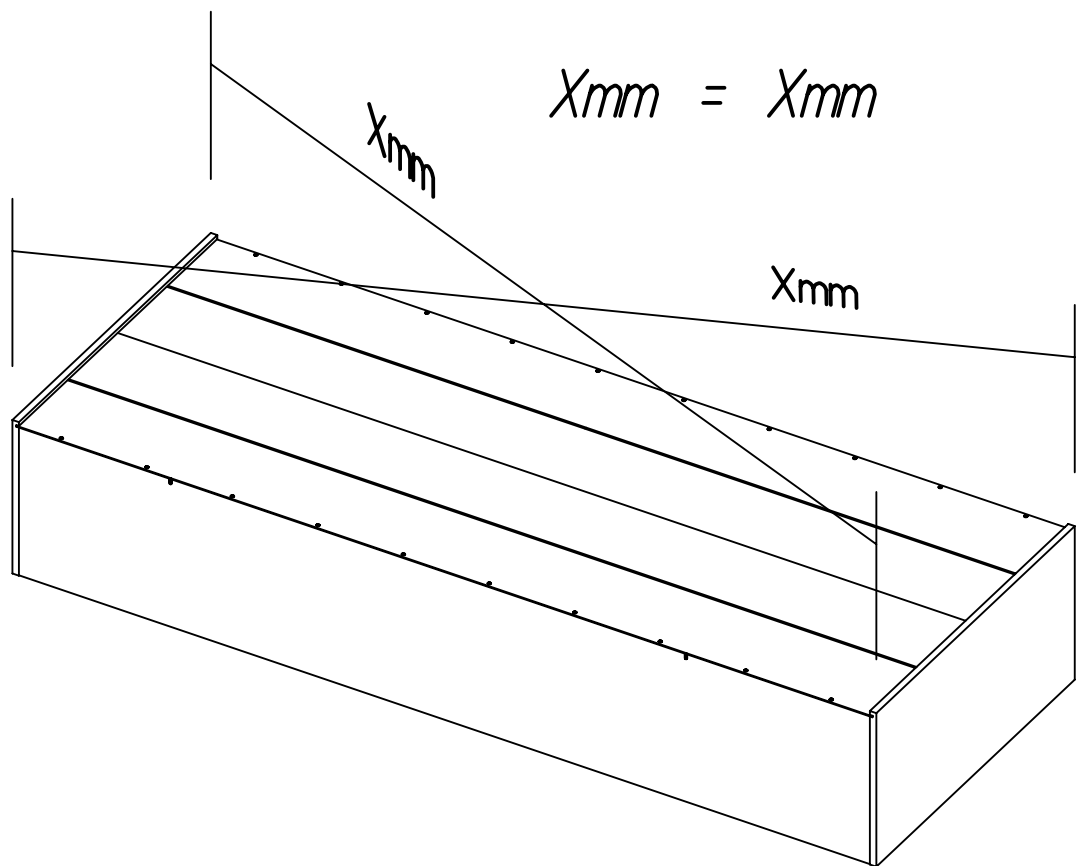
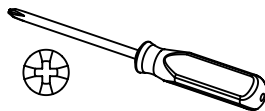
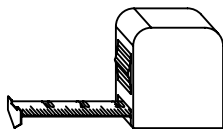

27

10x

215

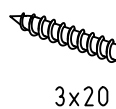

3x20

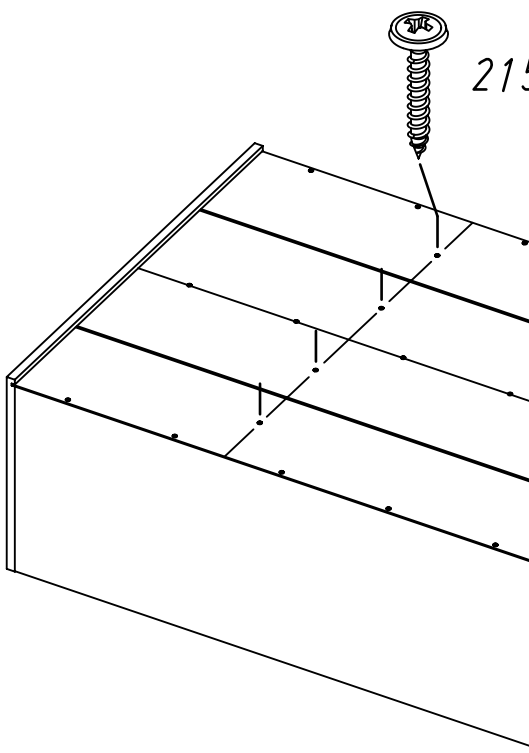
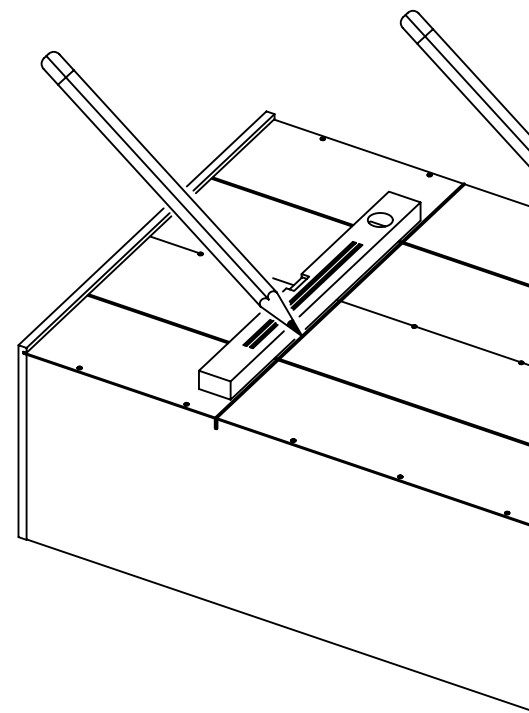

28

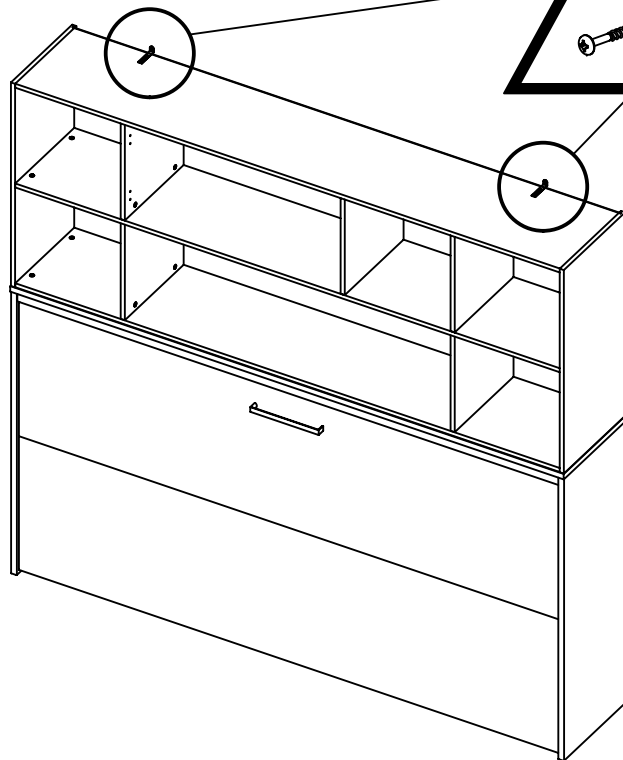
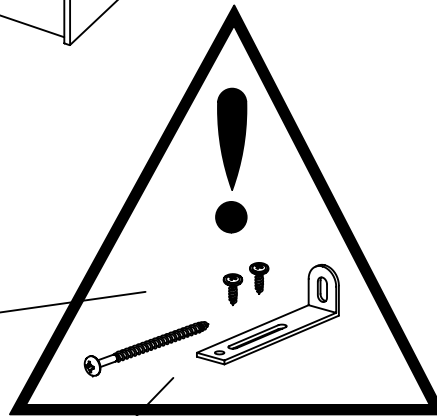
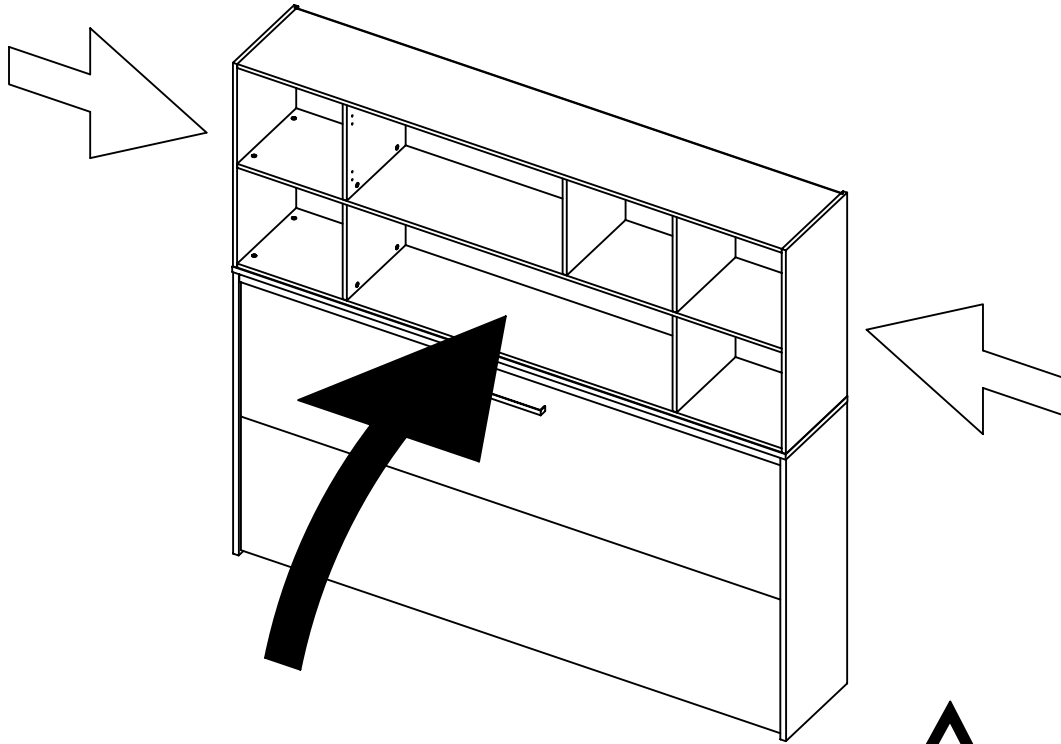
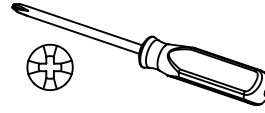
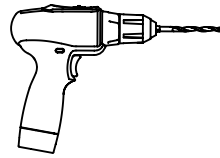

29

6x 116

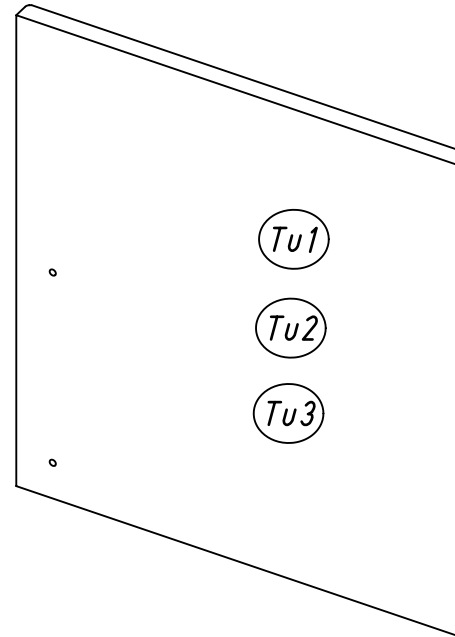
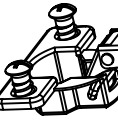

30

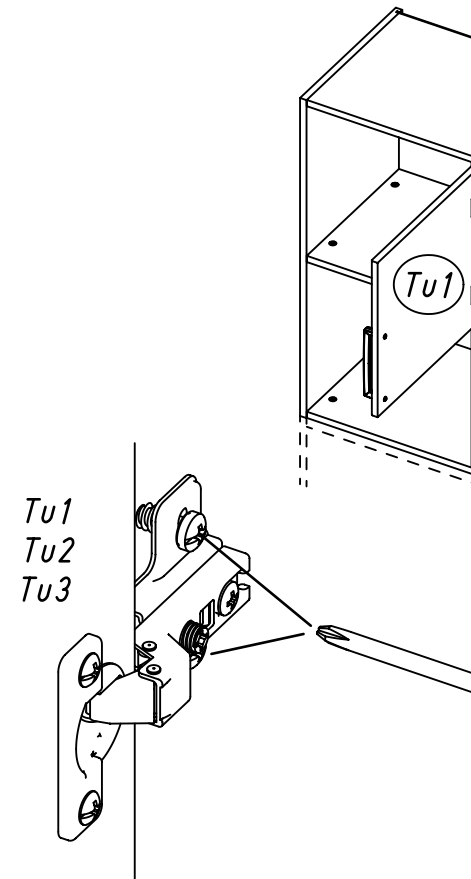

31

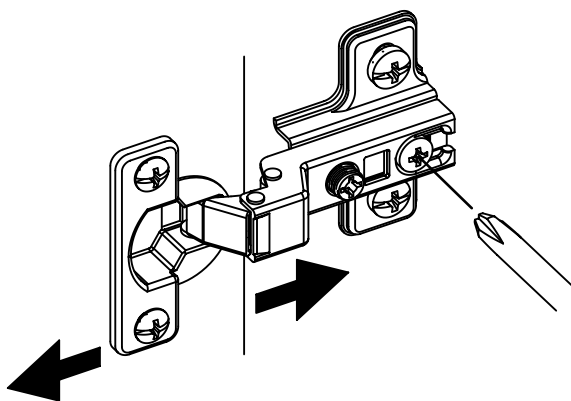
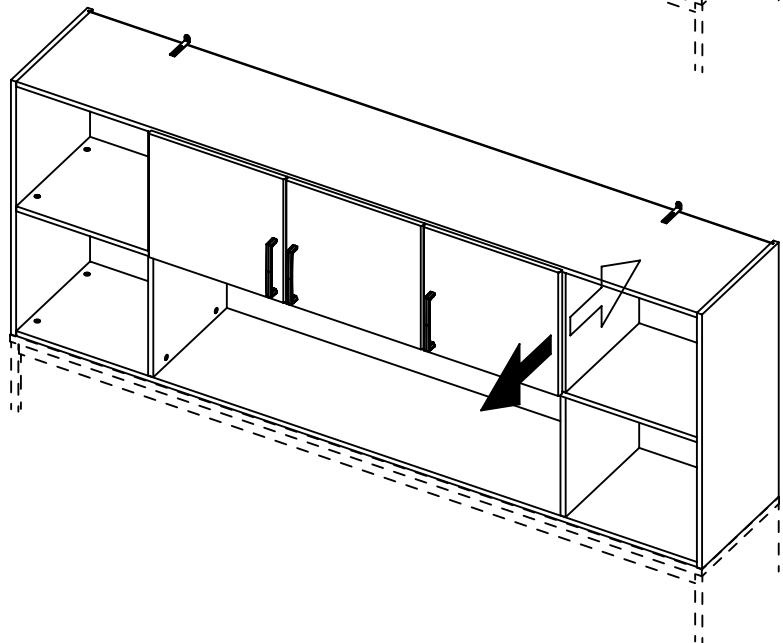
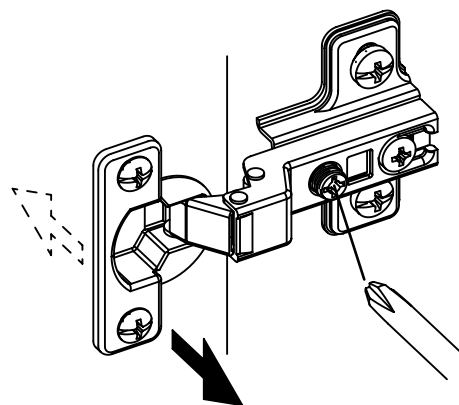
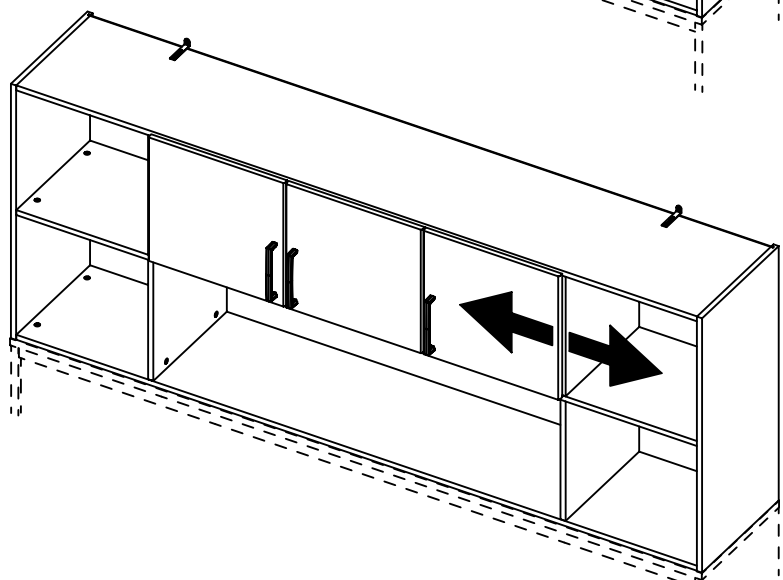
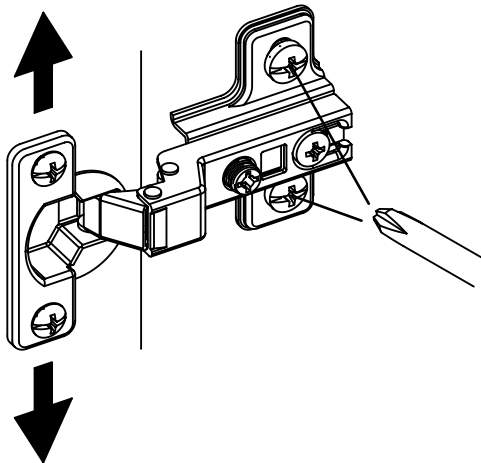
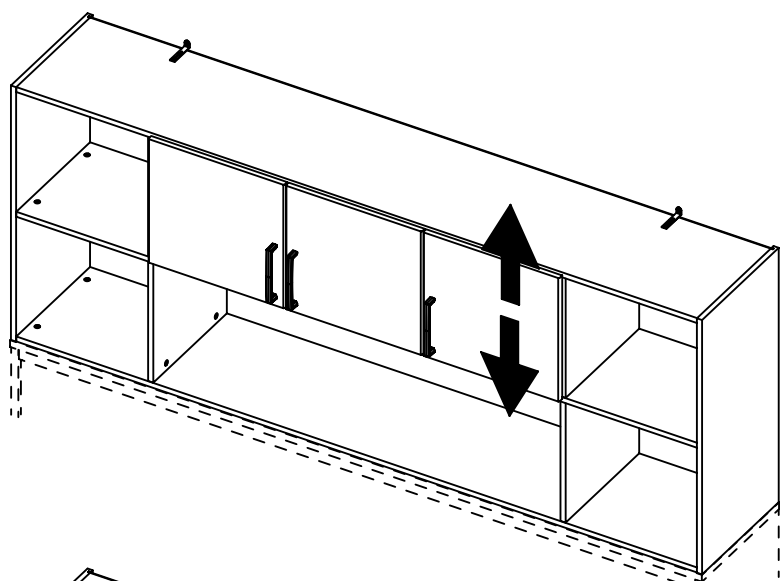
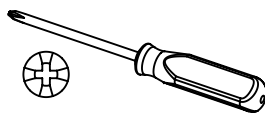

32

8x

203

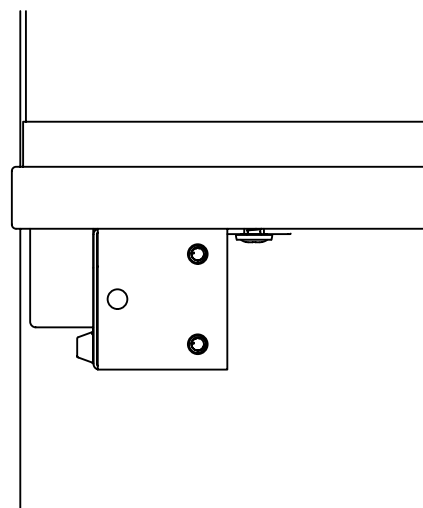
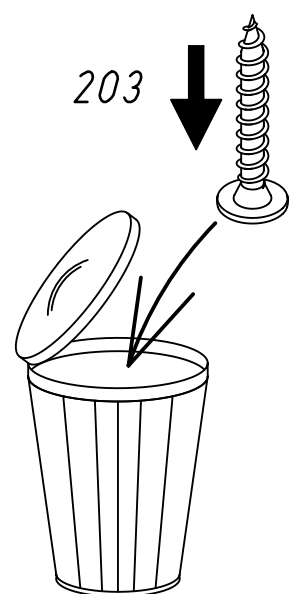

33

8x 220

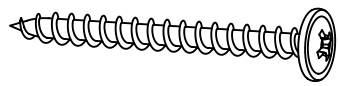

4x45

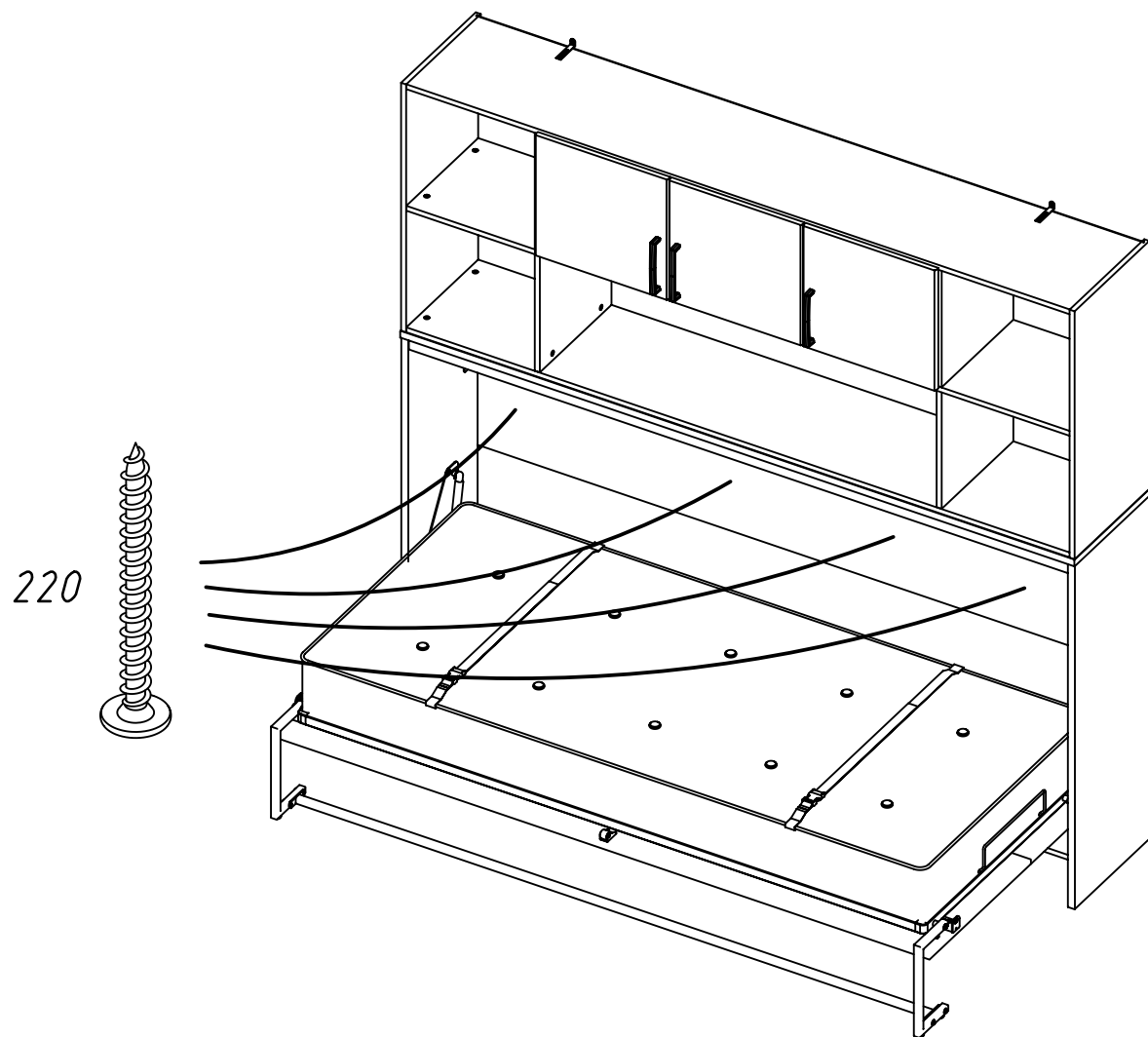
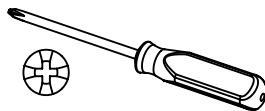

220

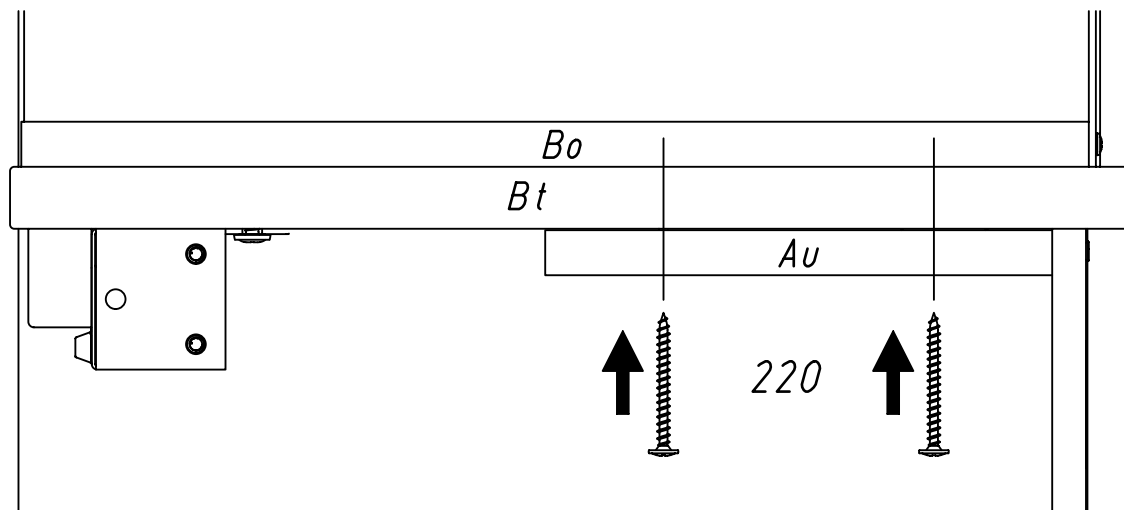

34

32x 449

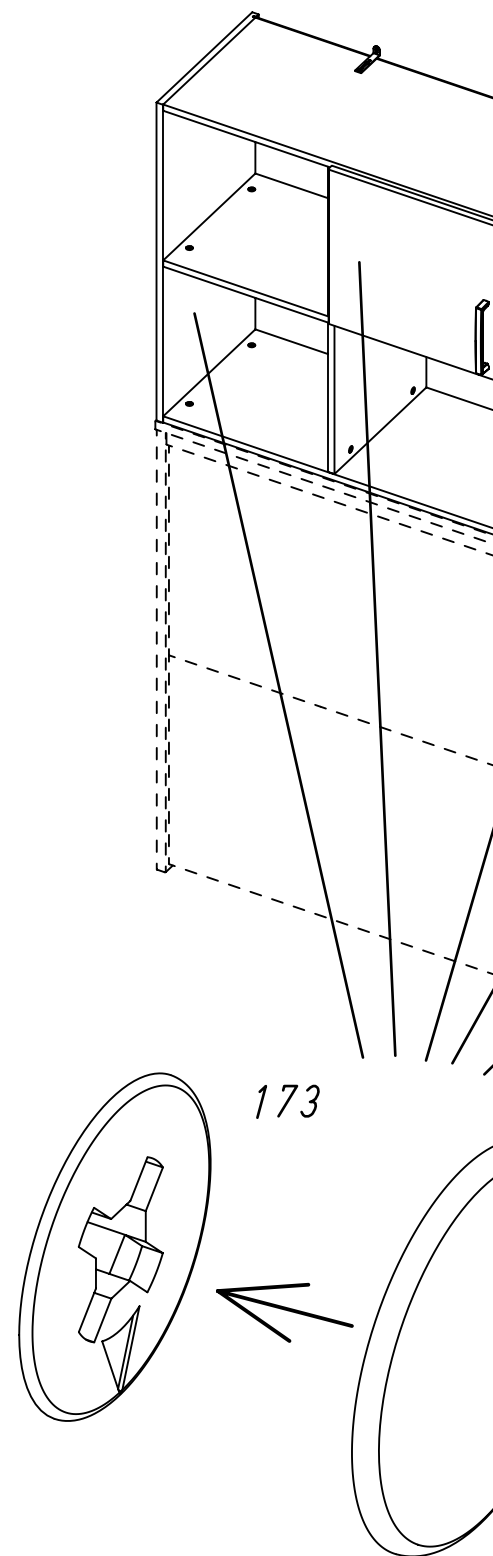

173

2.

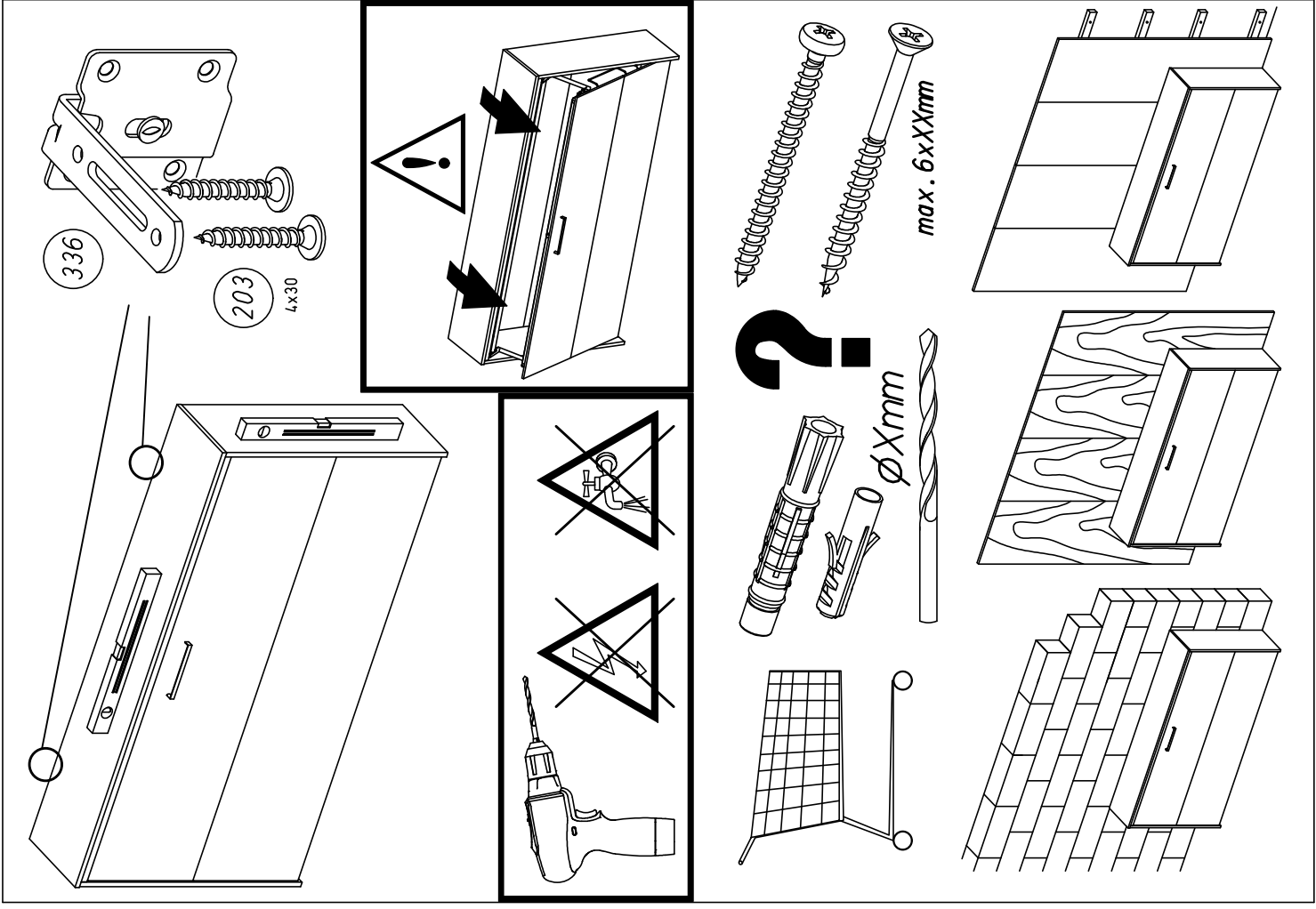

1.

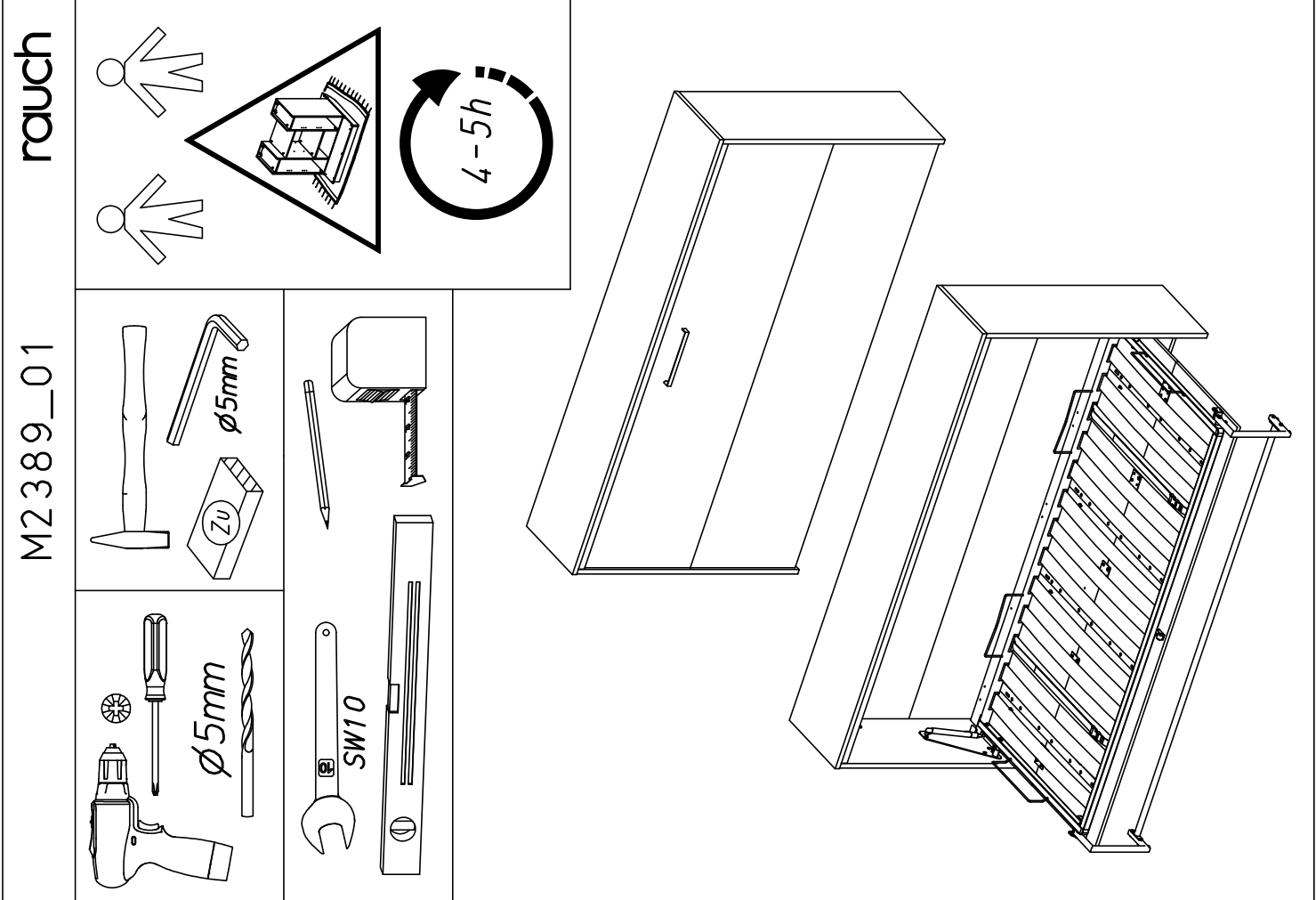

4.

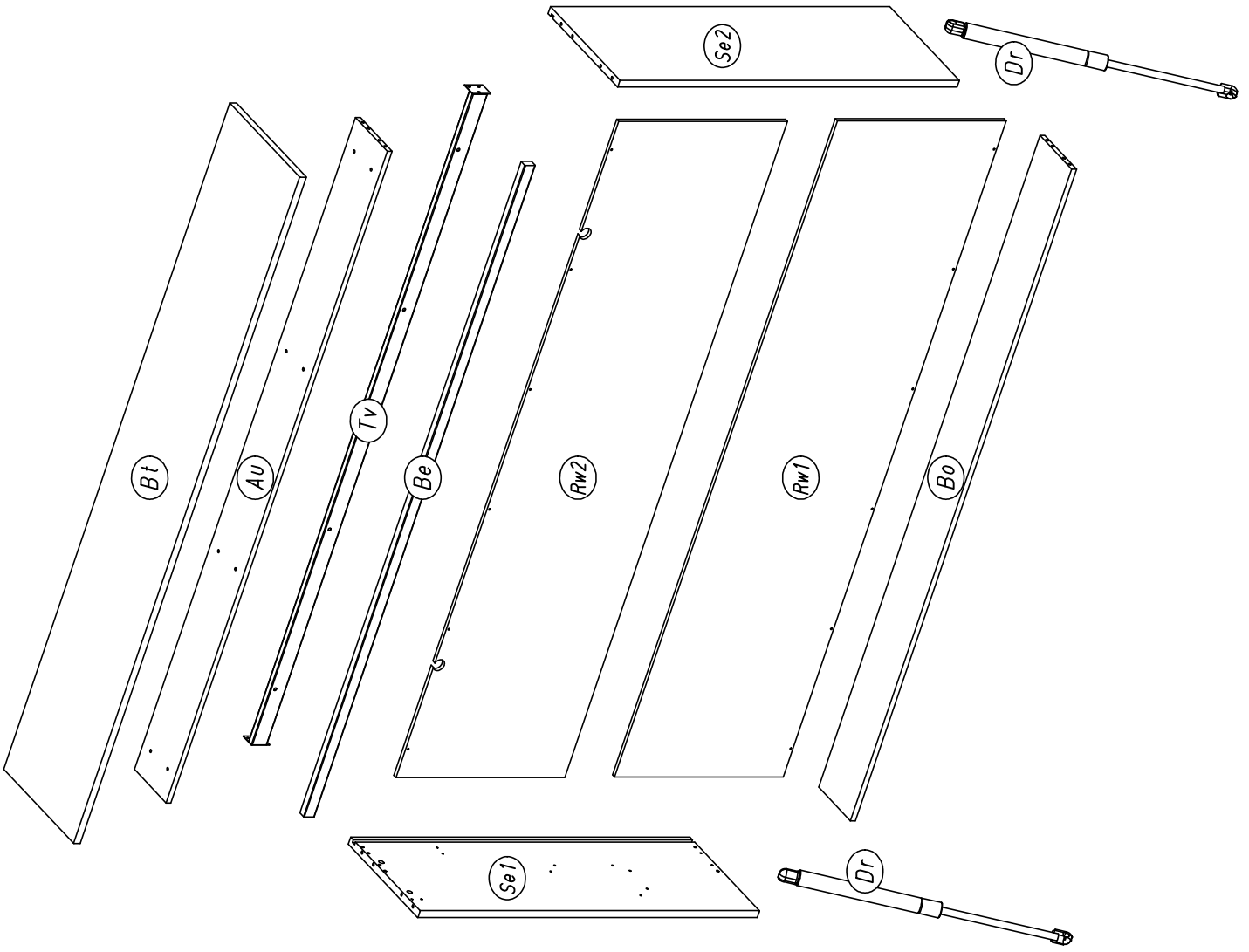

3.

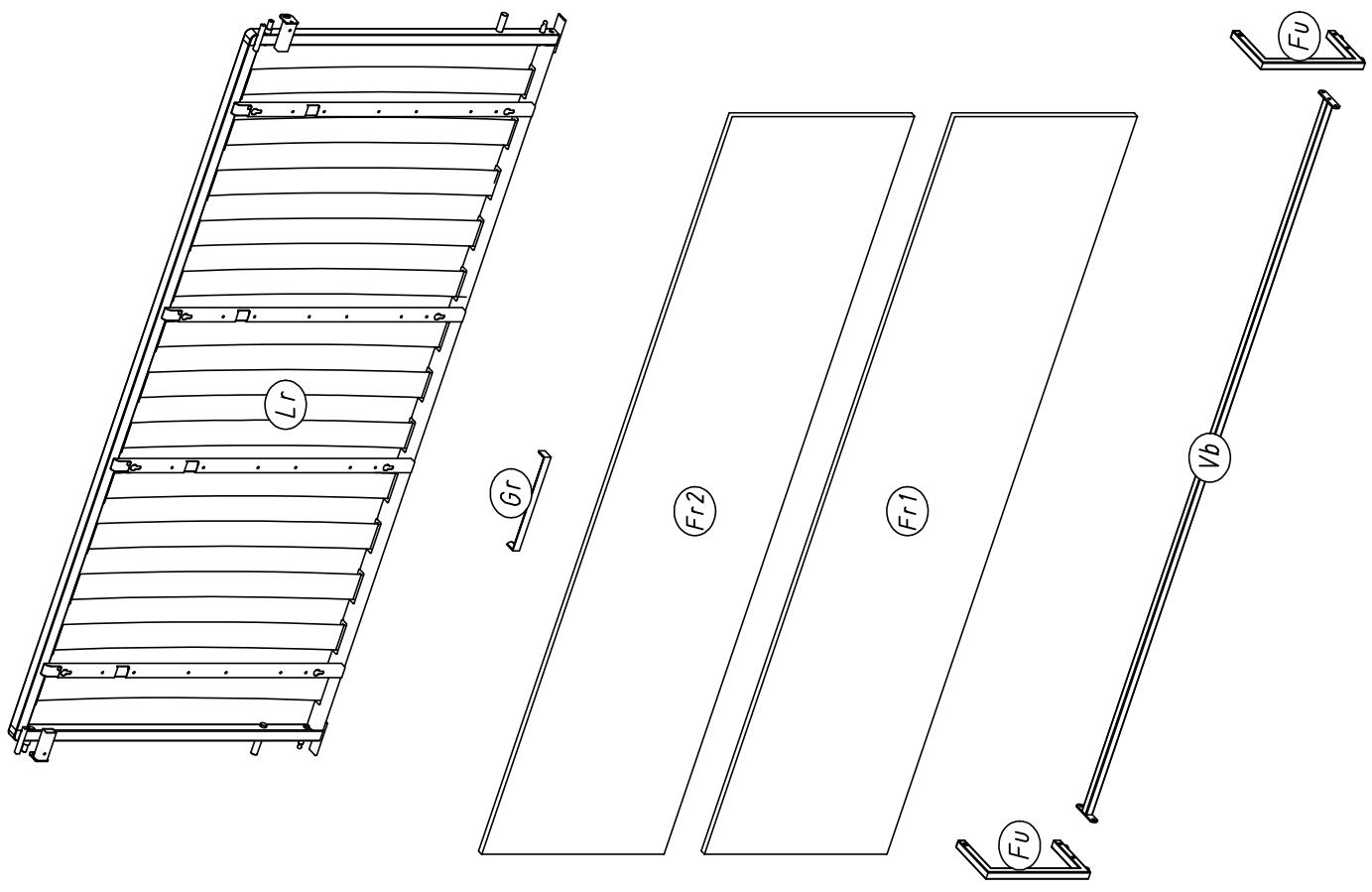

6.

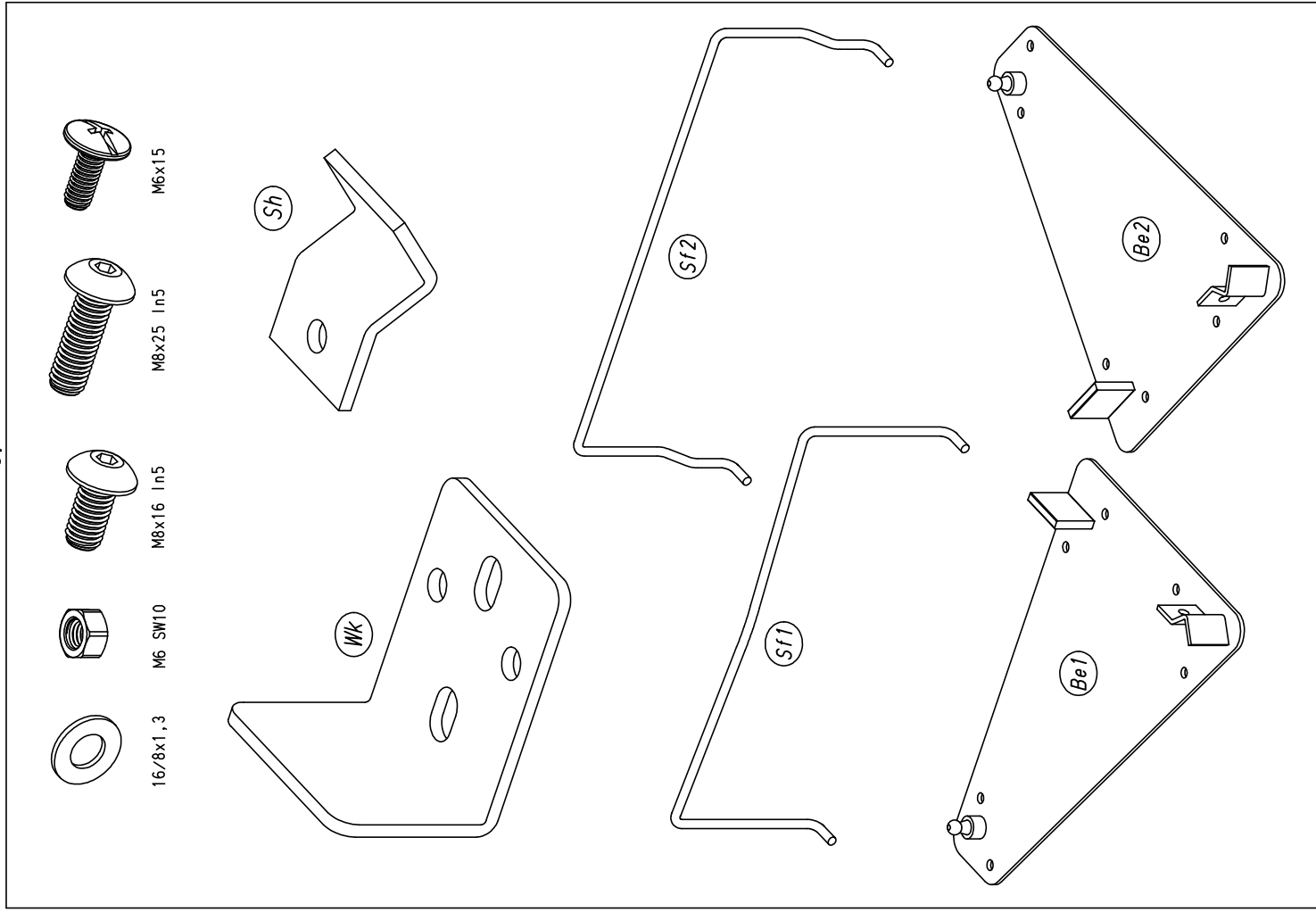

5.

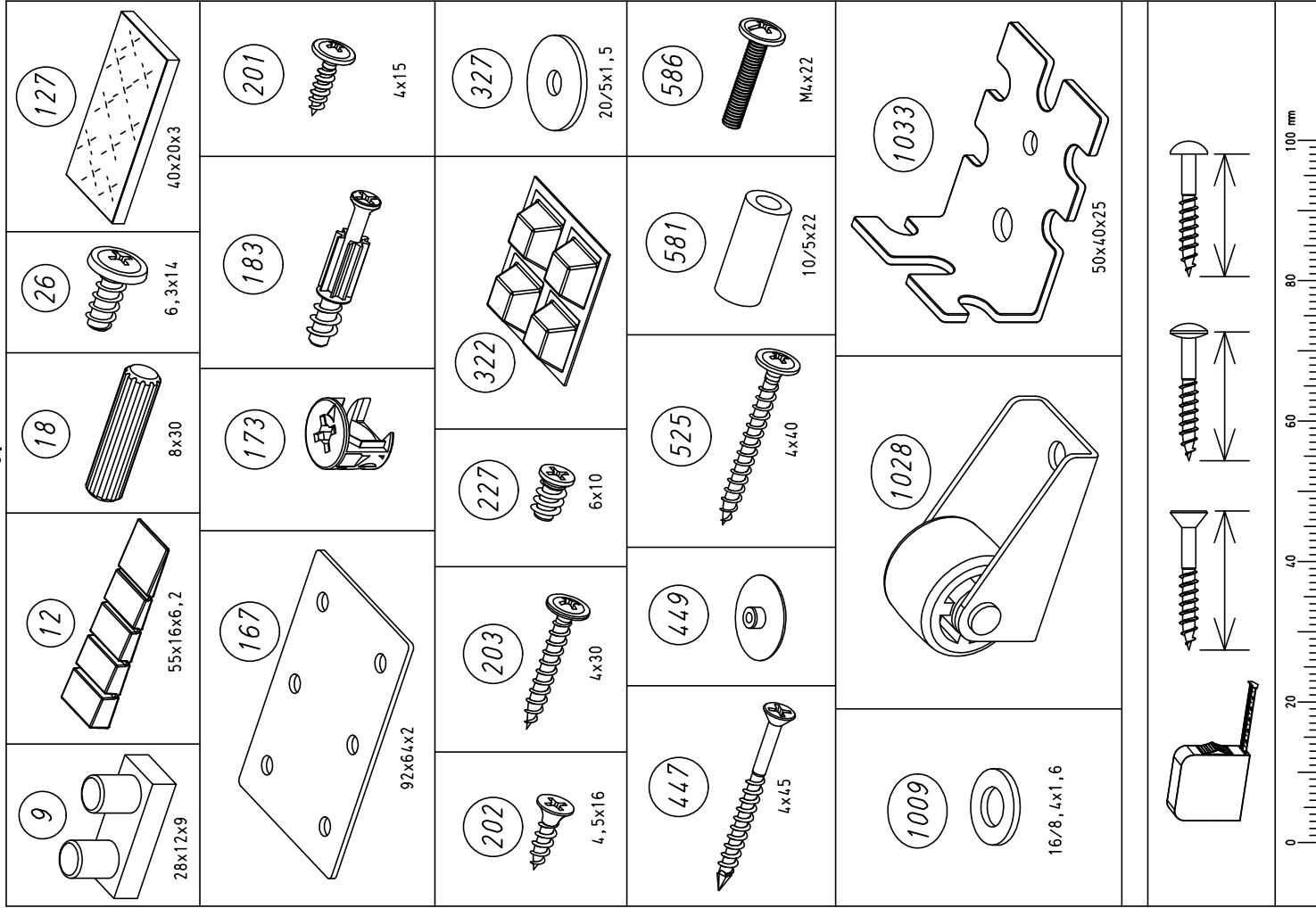

7.

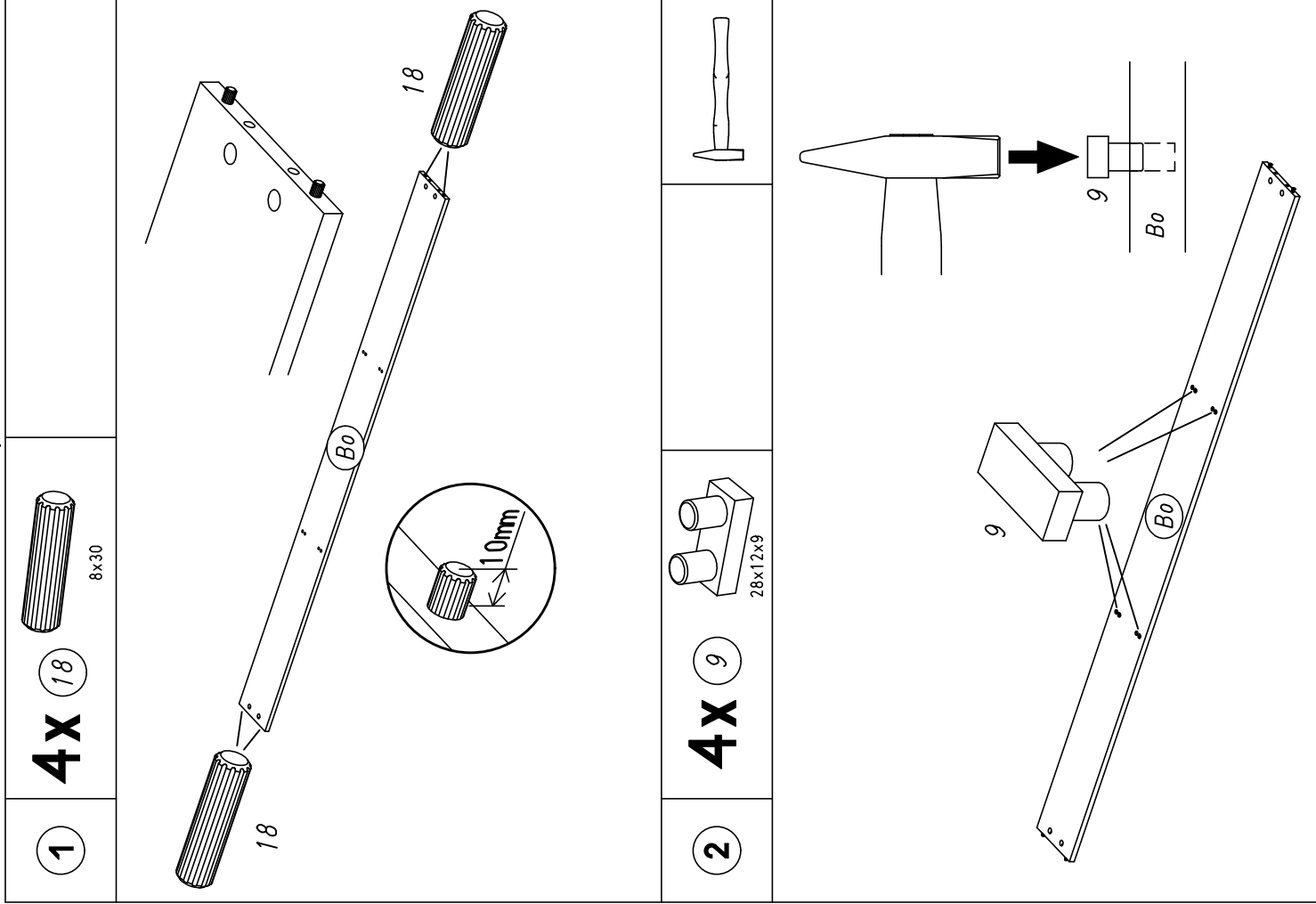

M2389

8.

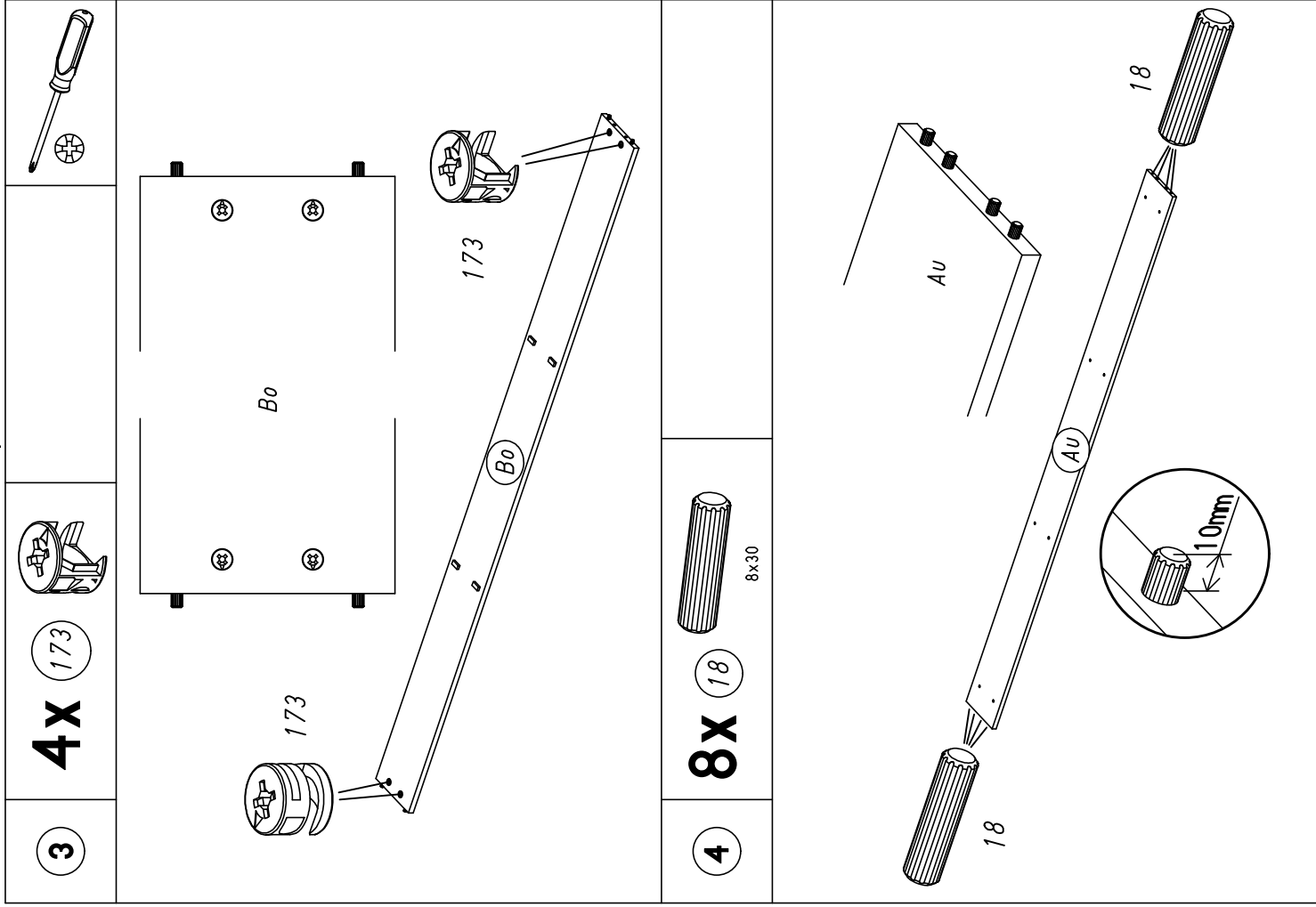

M2389

9.

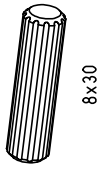

5 **4X** 18 8x30

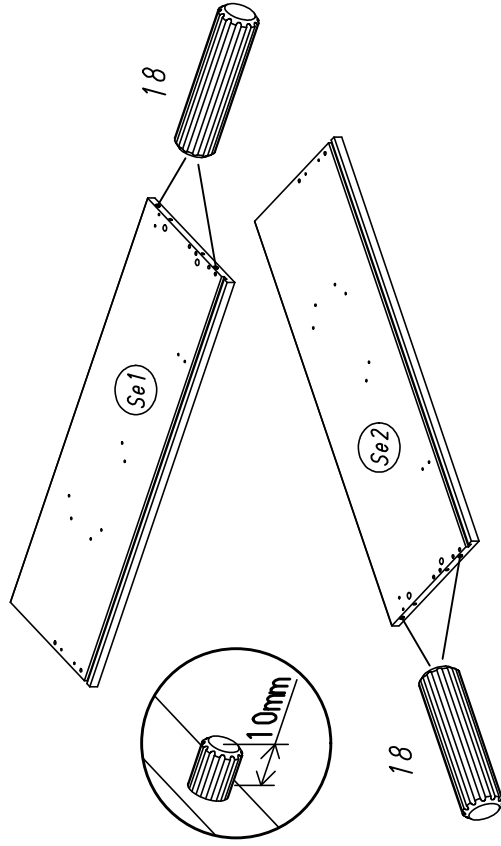

6 **4X** 173

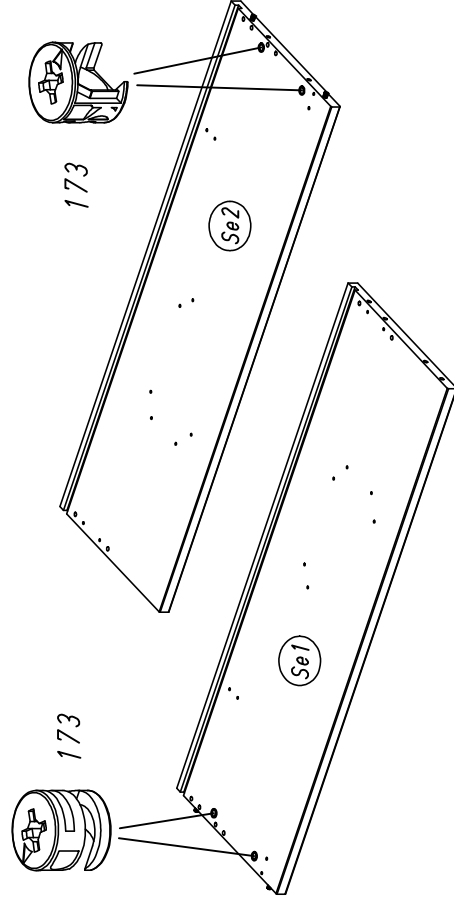

10.

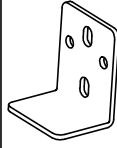

7 **2X** MK 26



4X 26 6,3x14

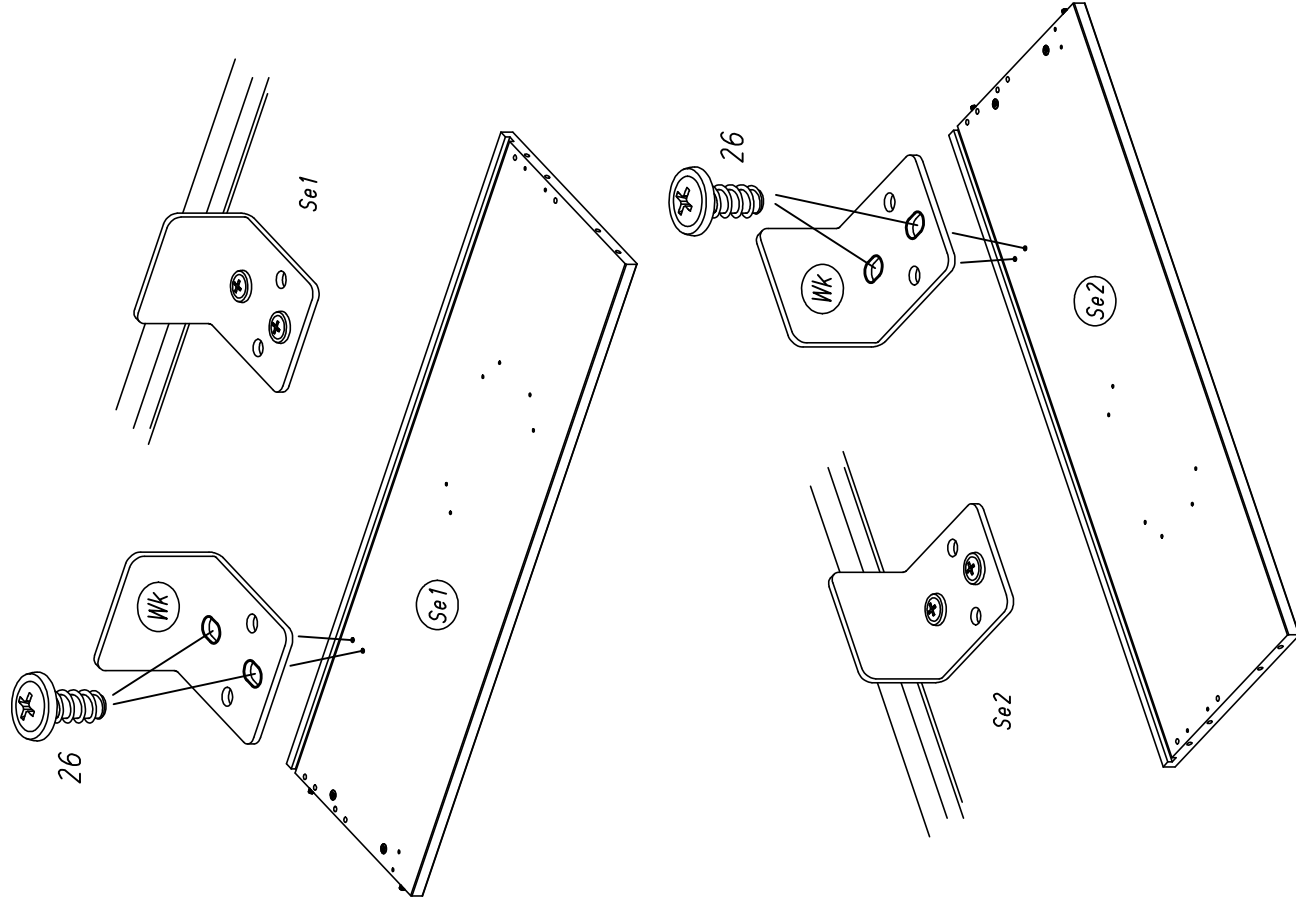

11.

8

12X



26

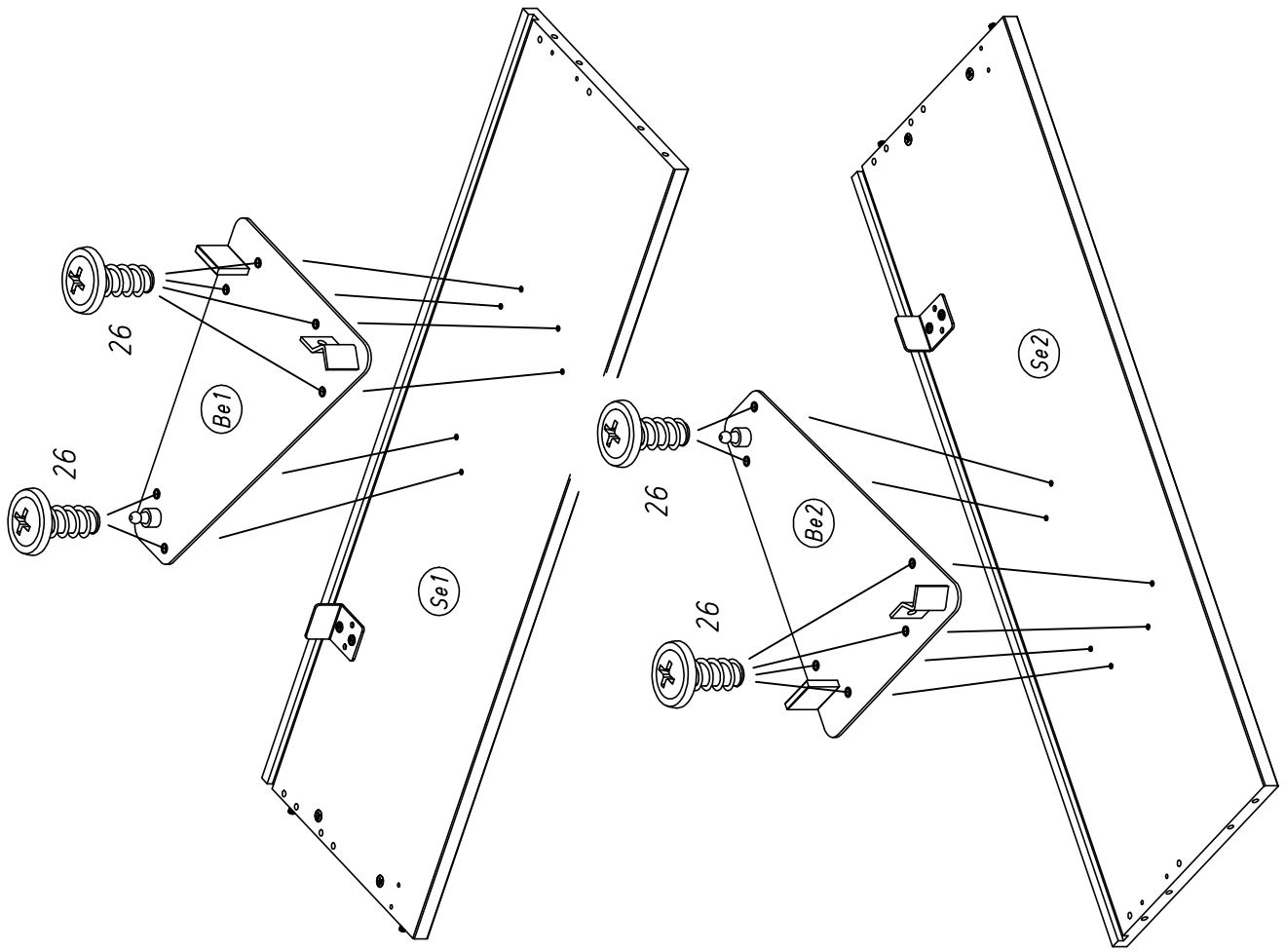

M2389

12.

9

4X



183

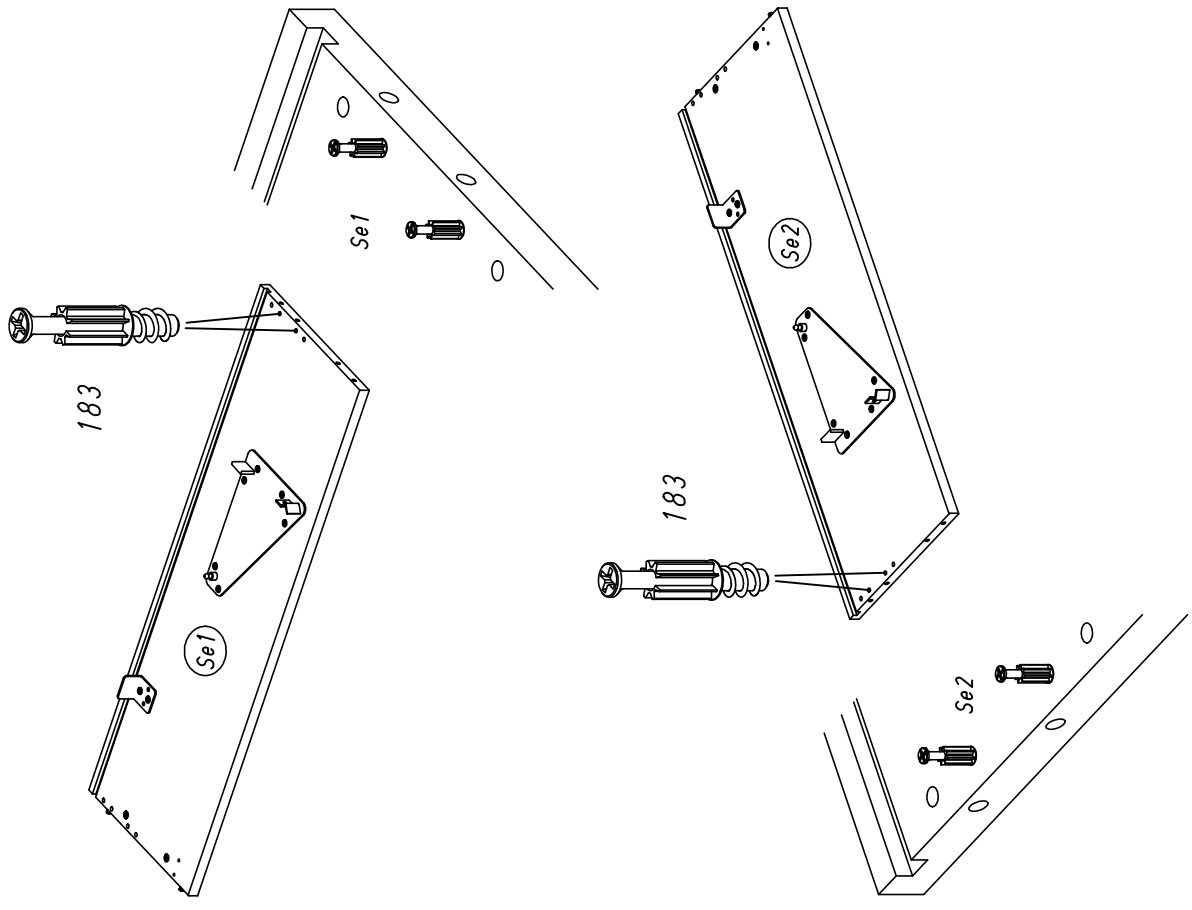

M2389

13.

10

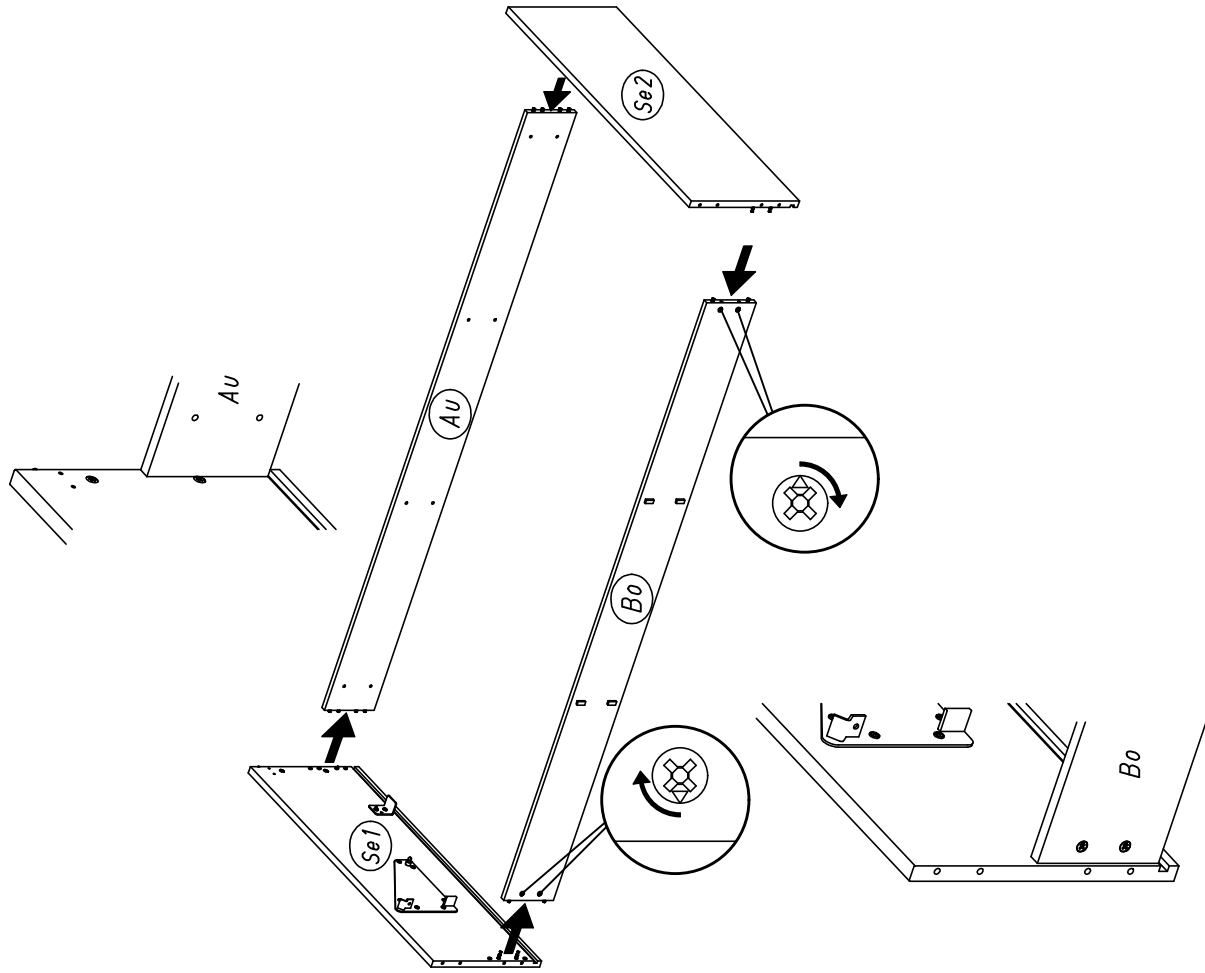

14.

11

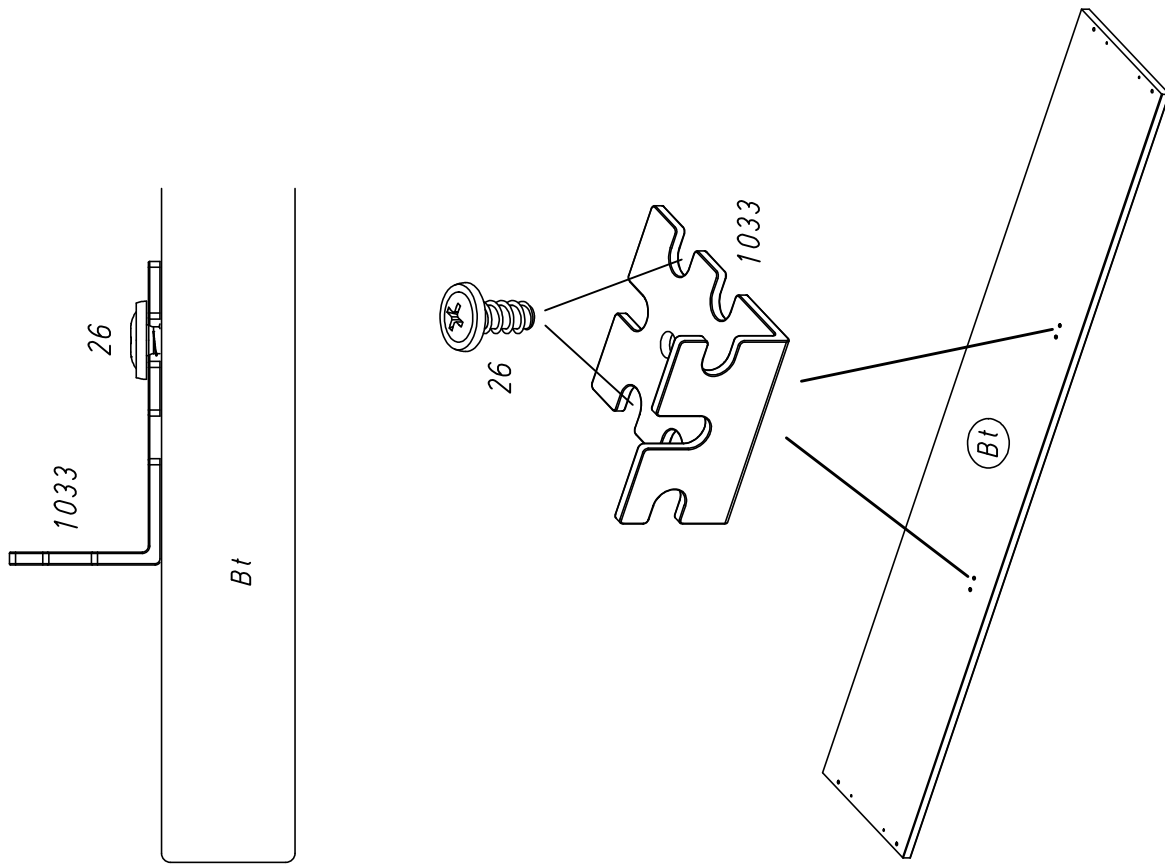
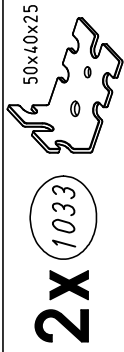

4x 26



15.

12

2X 327

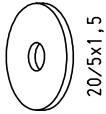

20/5x1,5

2X 525

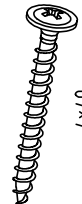

4x40

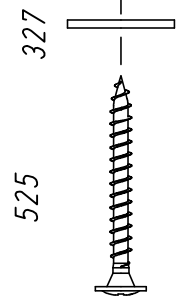
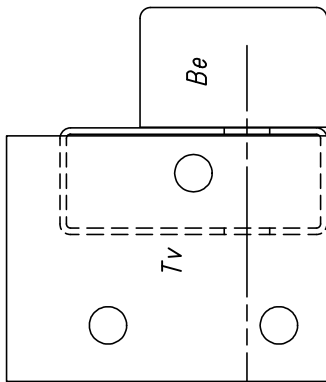
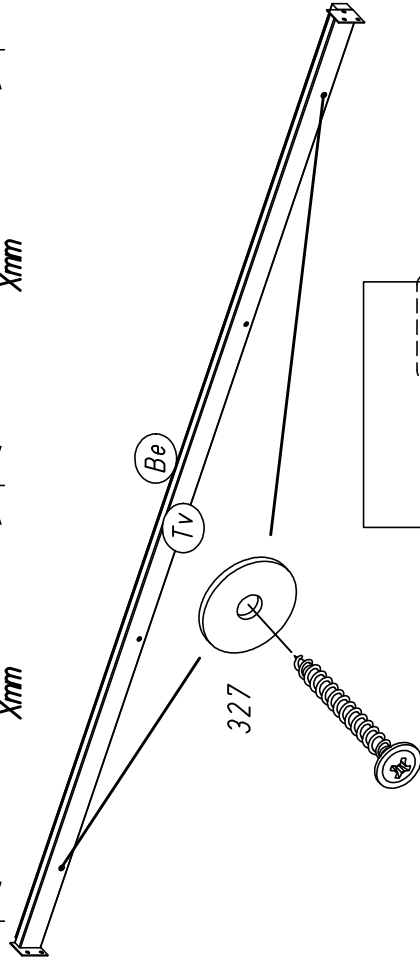
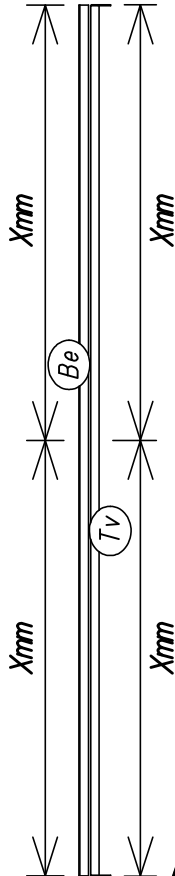
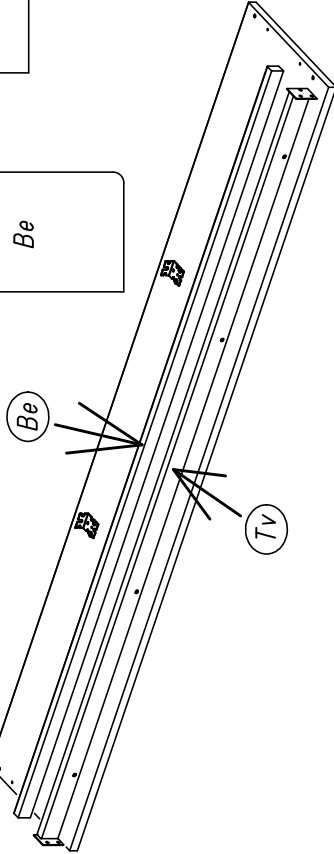
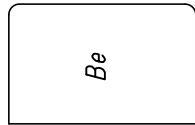
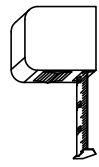

525

327

M2389

16.

13

2X 327



20/5x1,5

2X 525

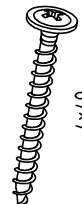

4x40

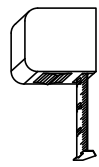

Xmm = Xmm

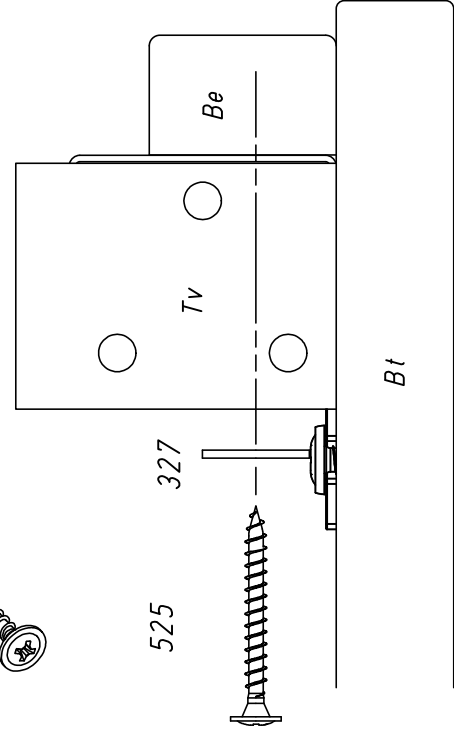
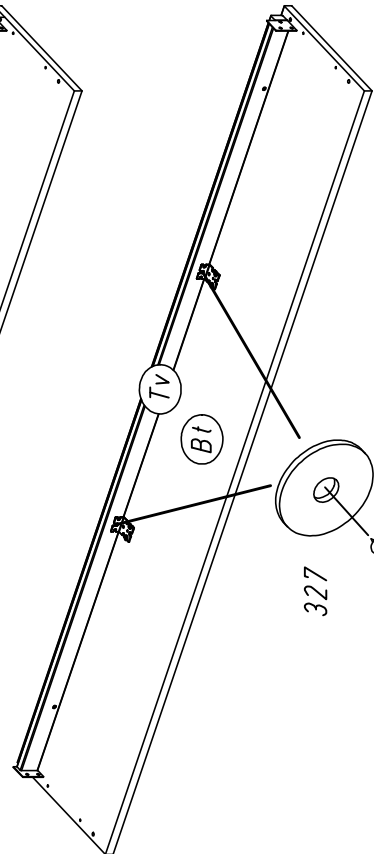
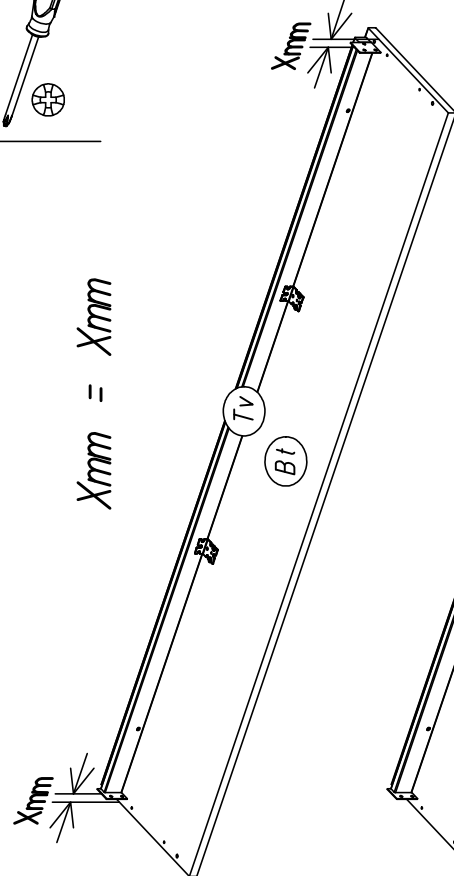

525

327

Bt

M2389

17.

14

4X 183

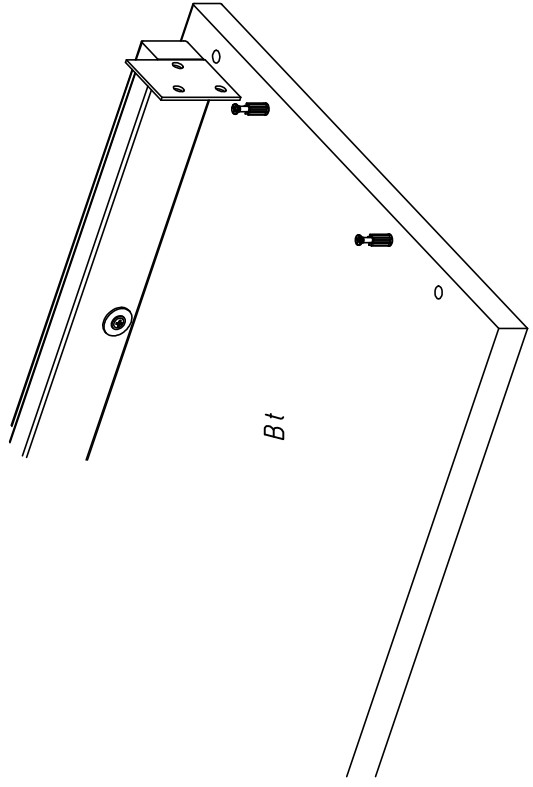
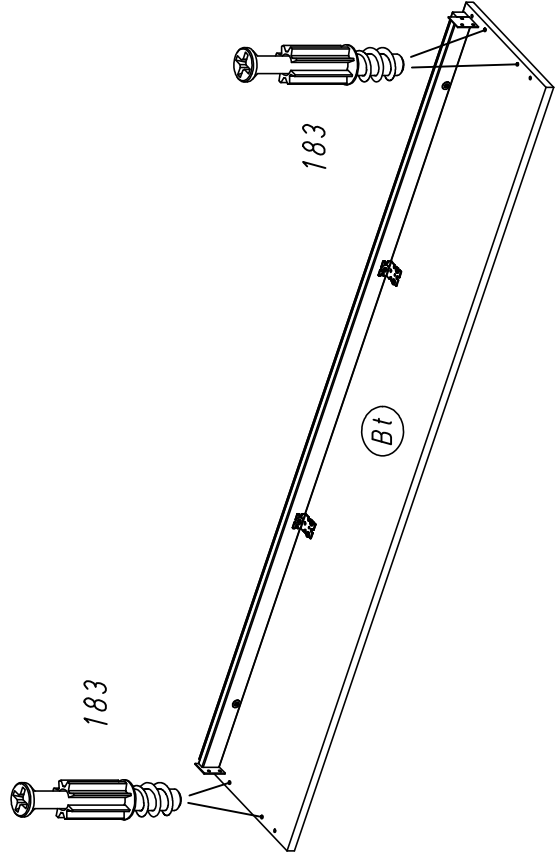
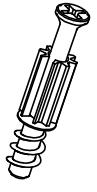

M2389

18.

15

8X 203

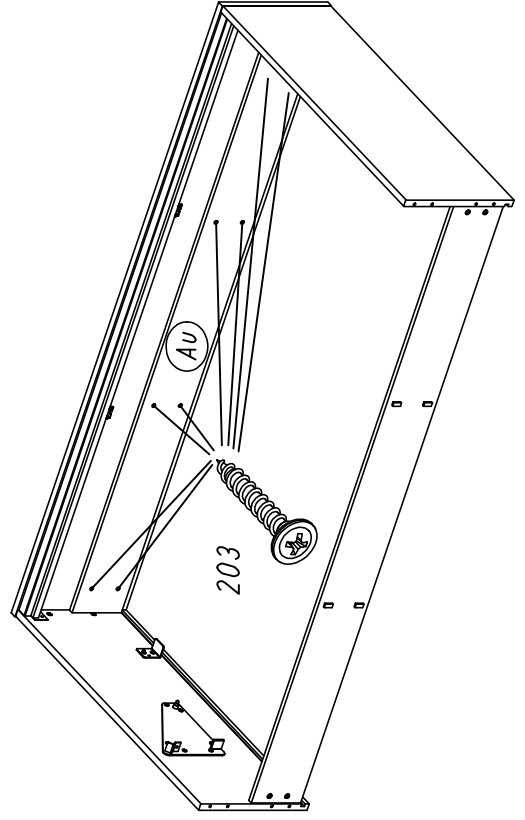
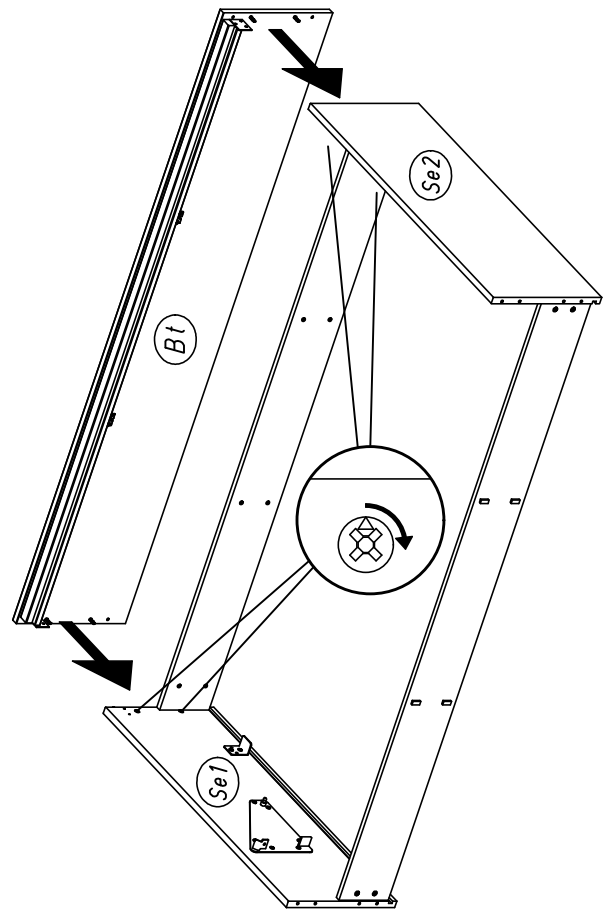
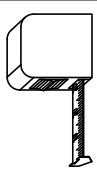
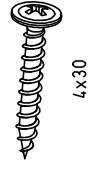

M2389

19.



4X 26

16

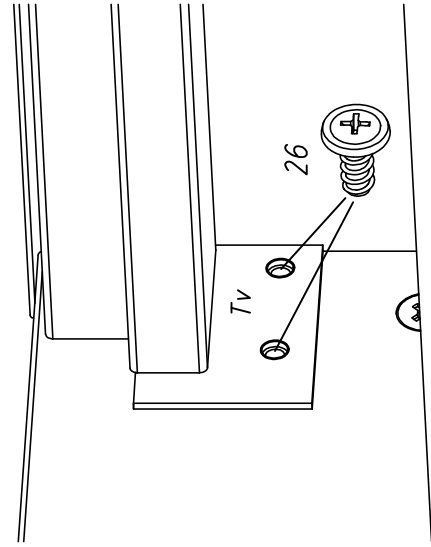
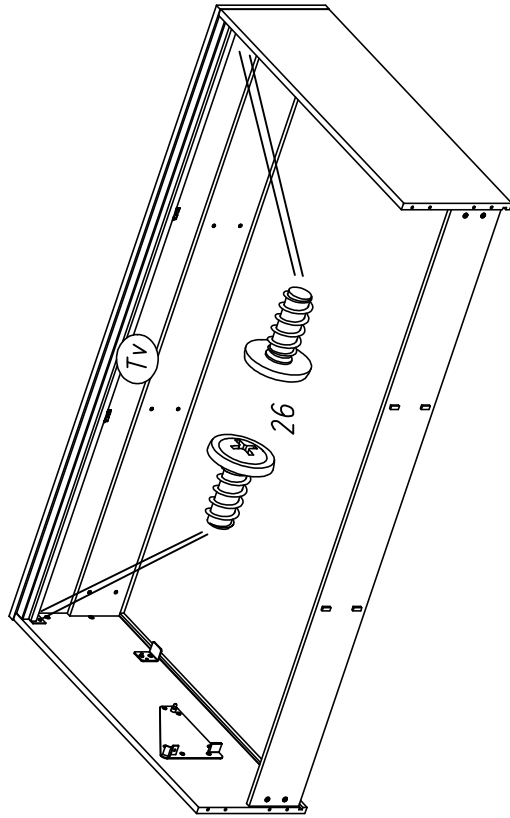

20.

17

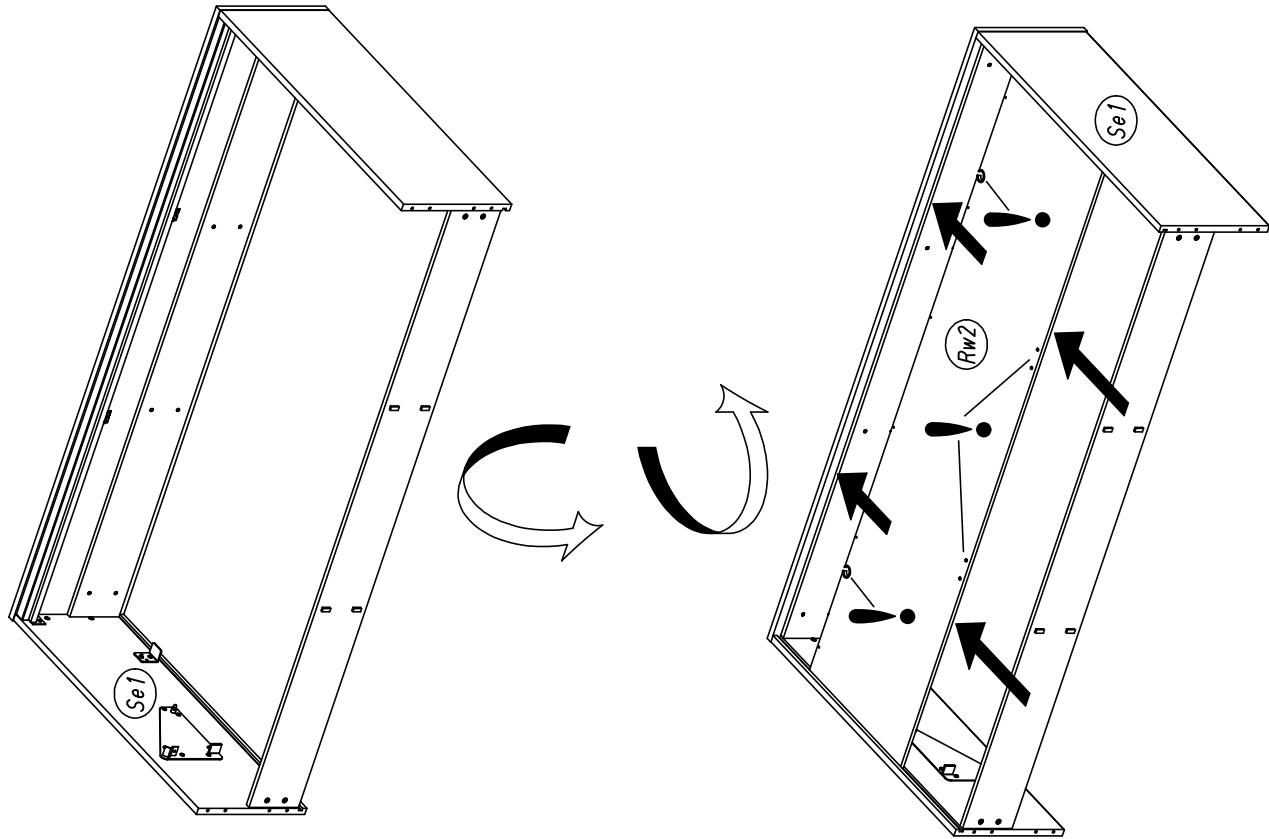

21.

18

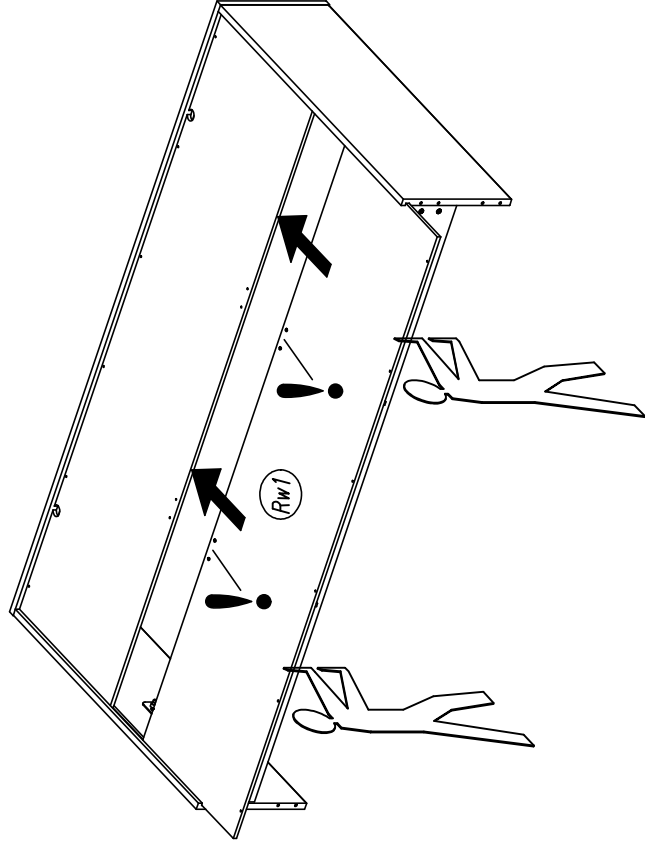

2X

167



8X

227

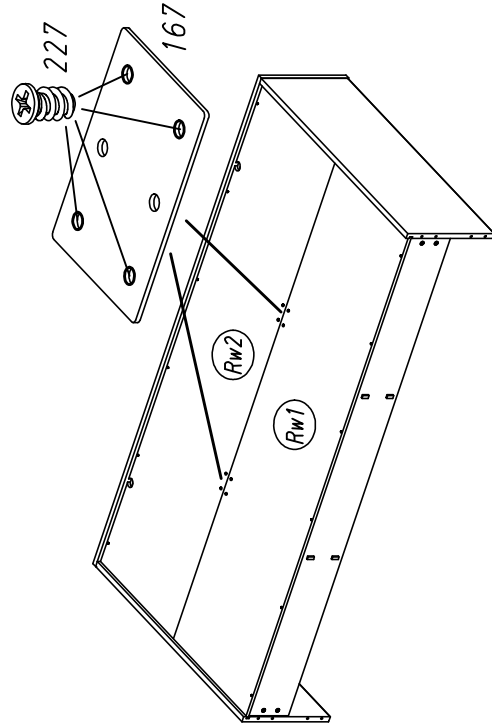

M2389

22.

20

12X

447

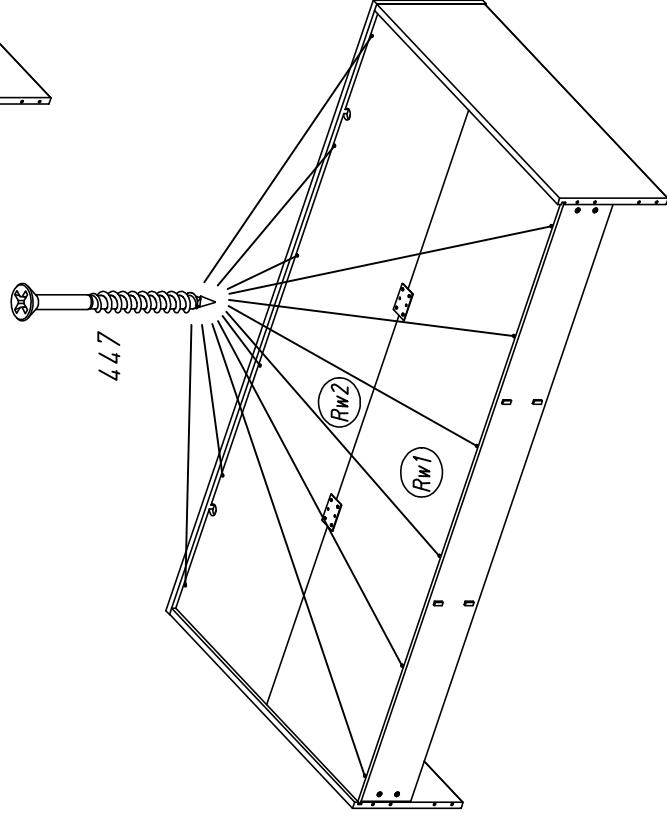
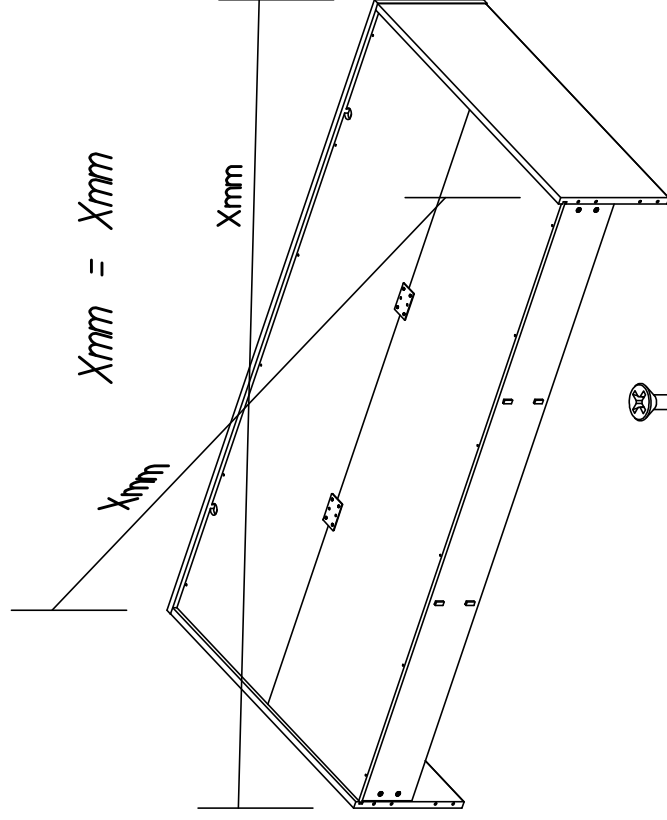
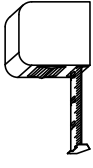
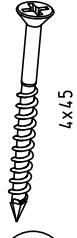

M2389

24.

22

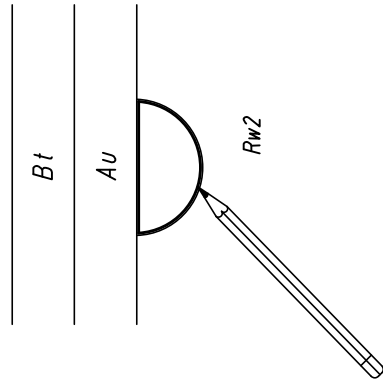
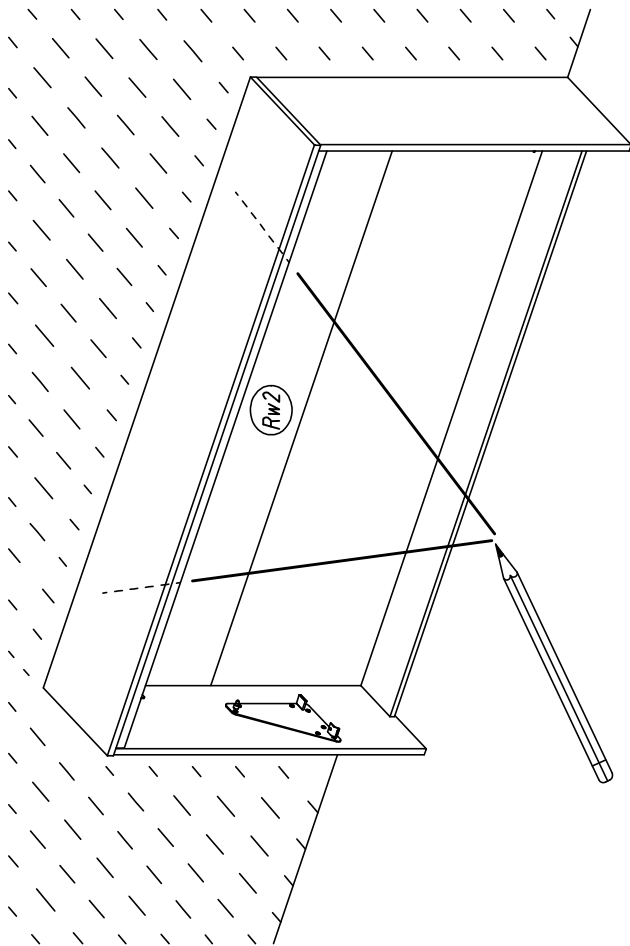

M2389

23.

21

2X

12

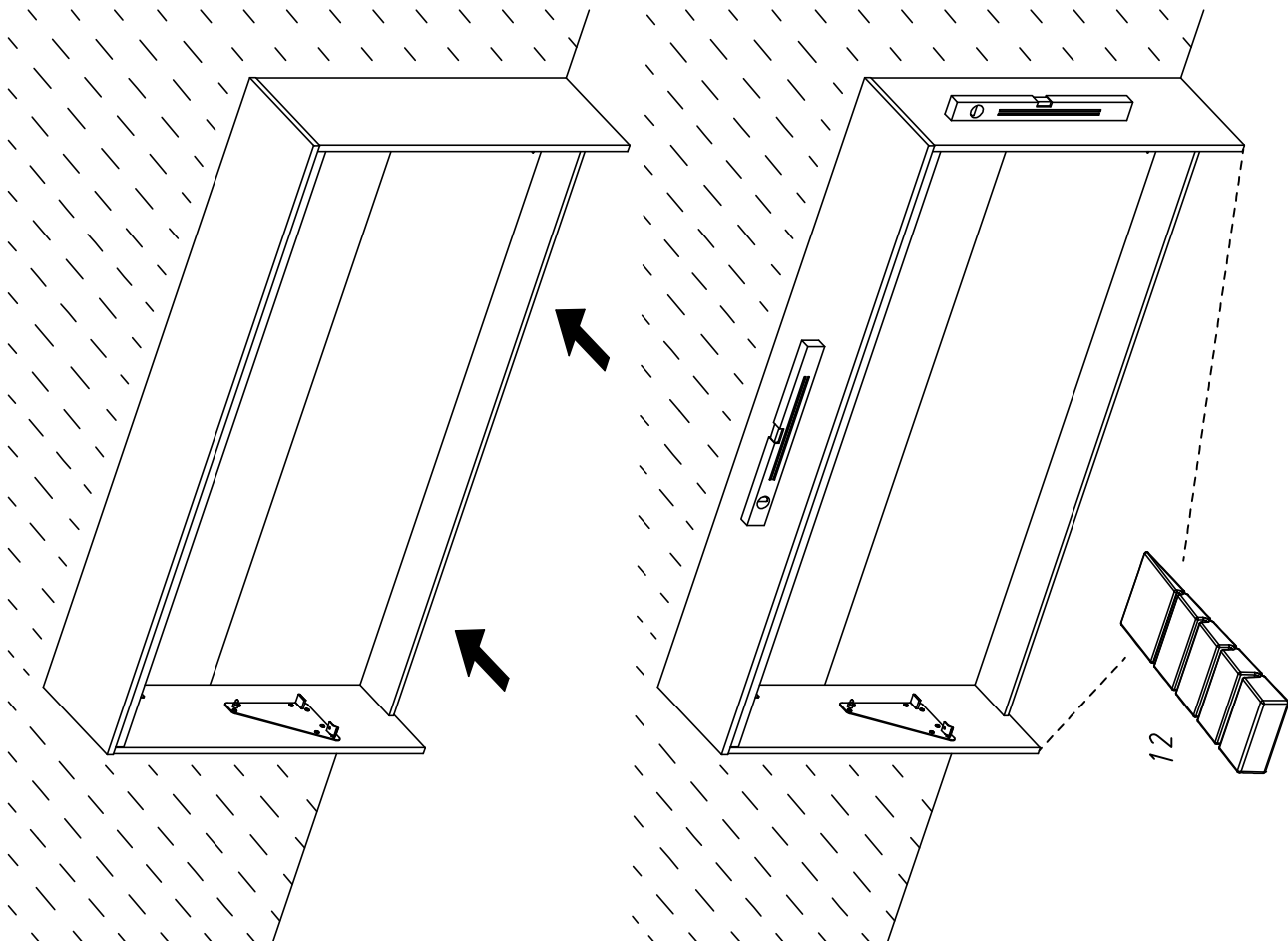
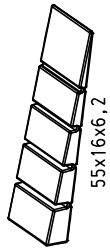

M2389

25.

23

1X

336

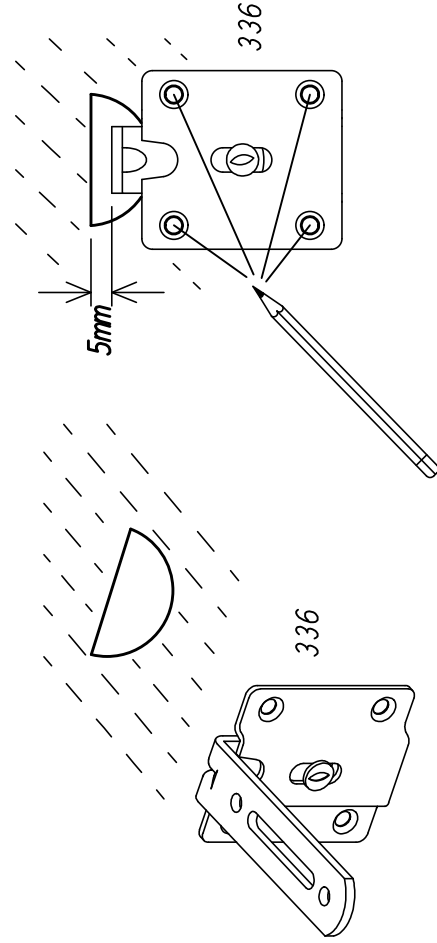
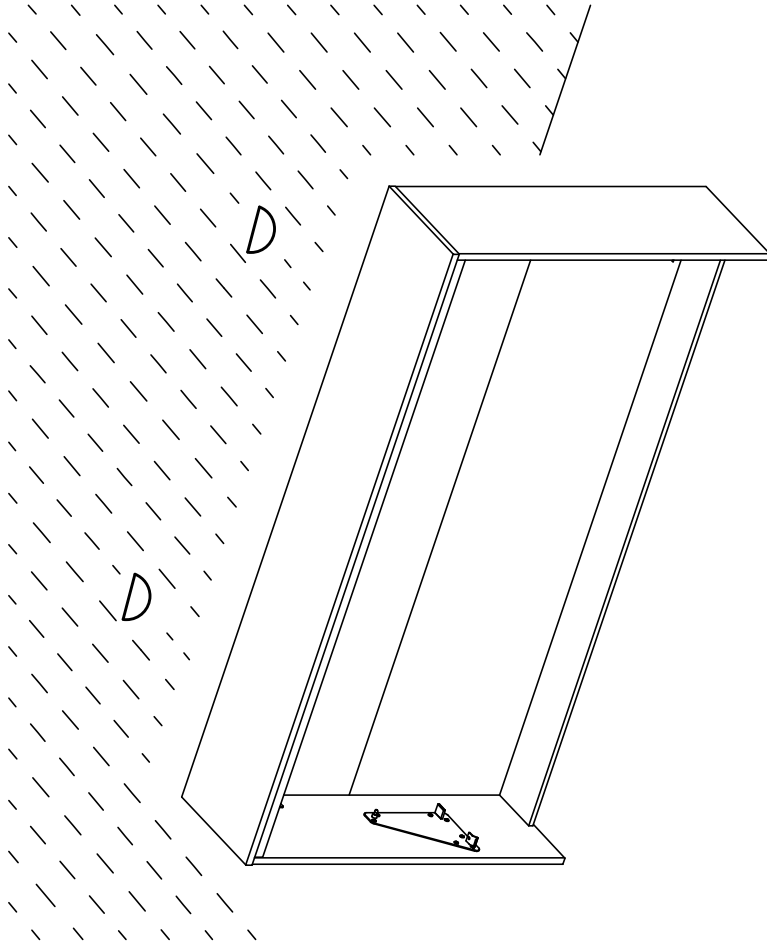
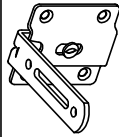

M2389

26.

24

2X

336

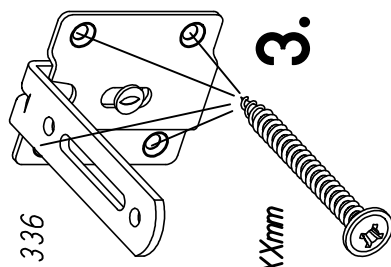
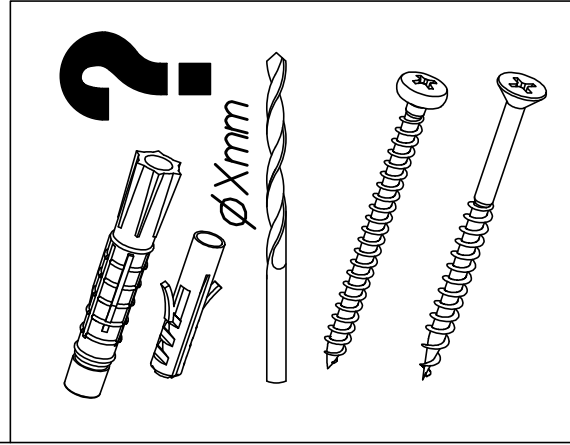
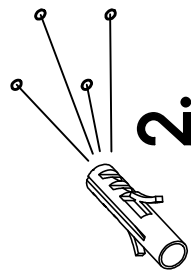
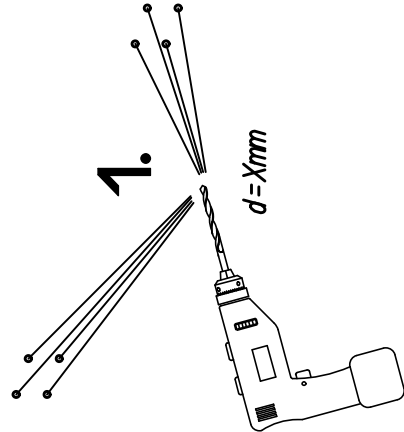
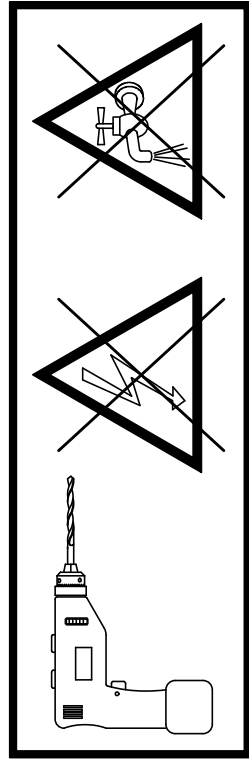
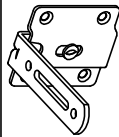

8X max. 6x Xmm

M2389

27.

25

4x

203

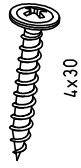

4x30

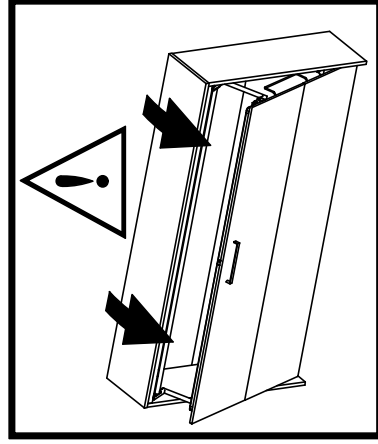
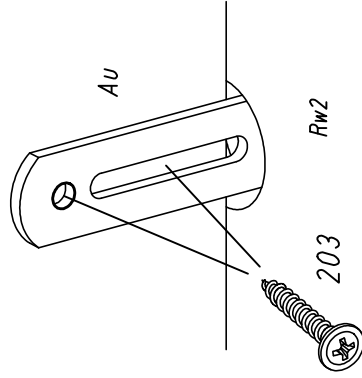
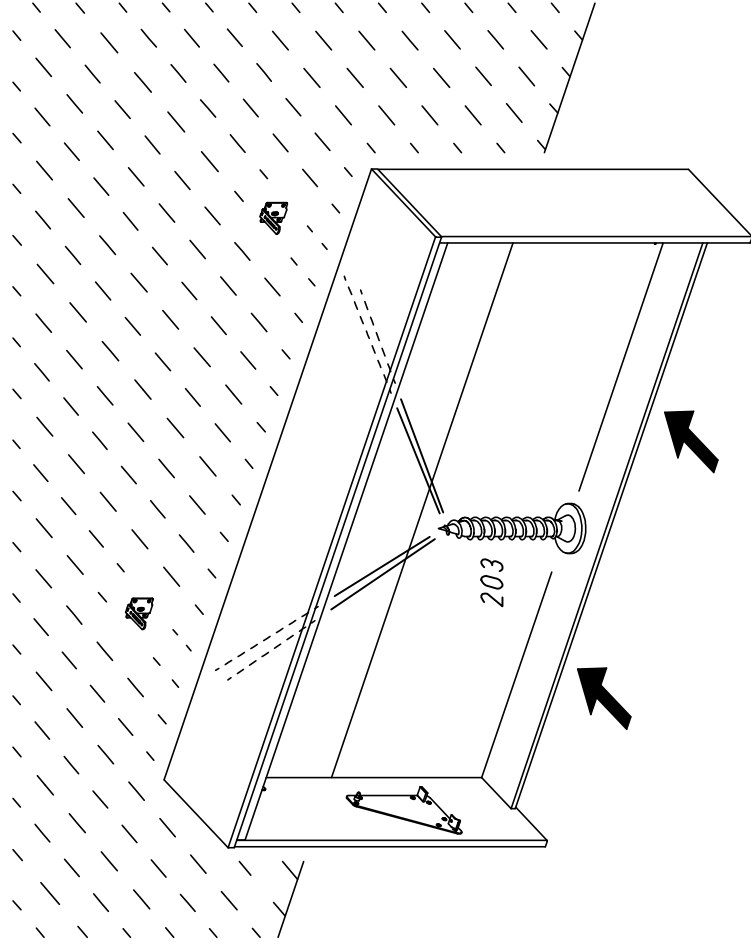

M2389

28.

26

1x

322

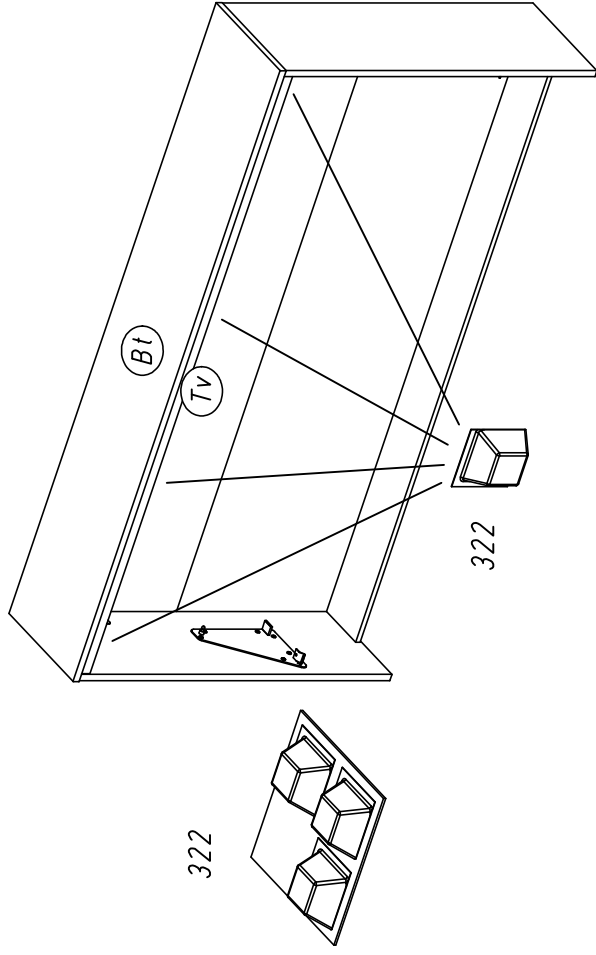
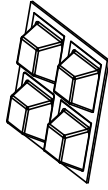

322

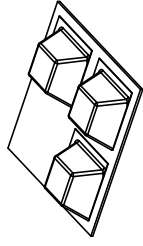

322

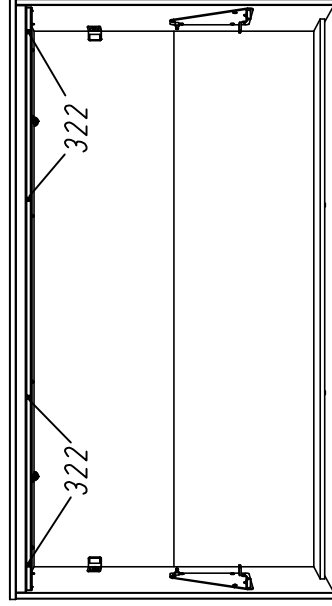

322

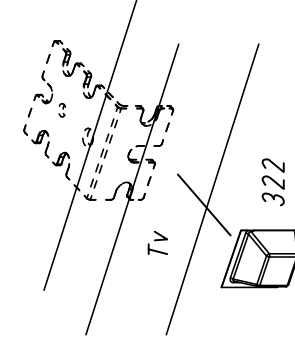

Tv

322

M2389

29.



40x20x3

2X 127

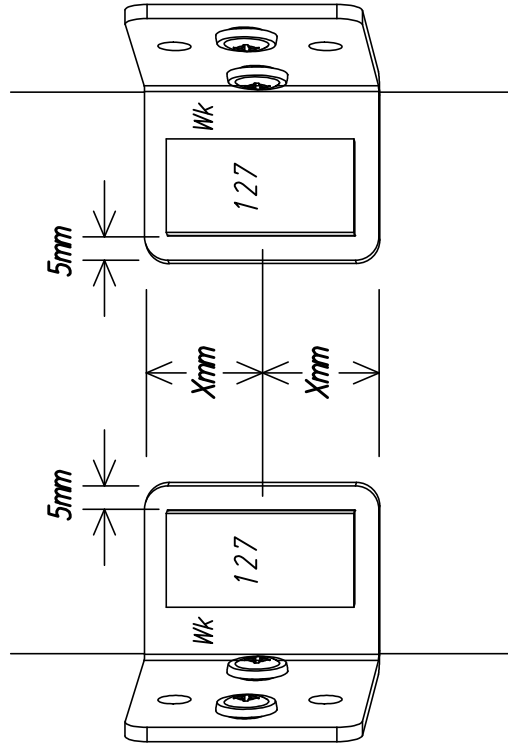
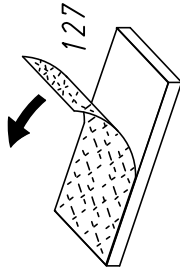
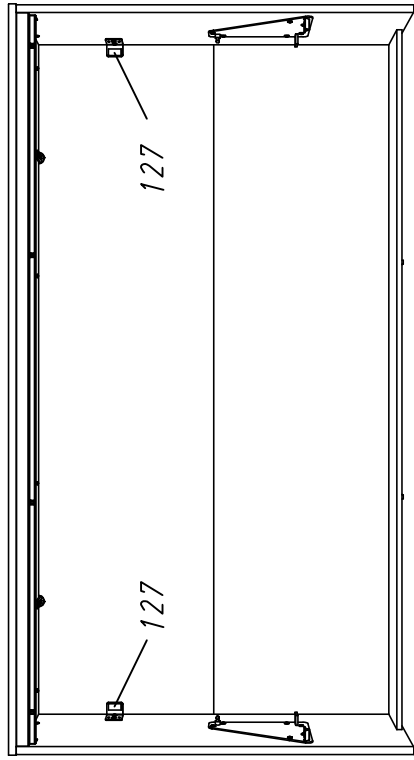

M2389

30.

28

2X M6 SW10



2X

M6x15



2X



16/8, 4x1, 6



2X 1009

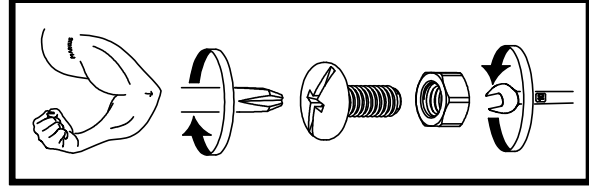
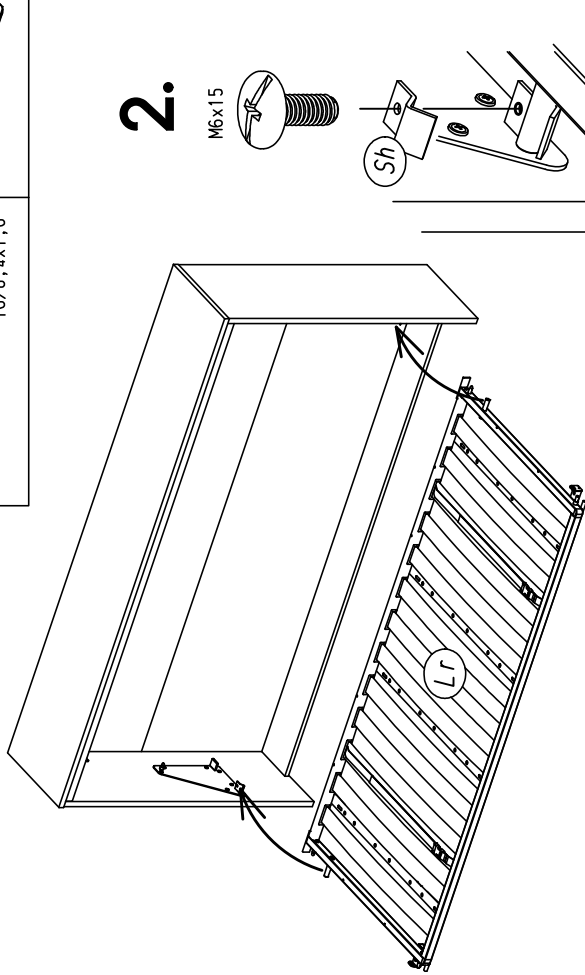

M2389

31.

29

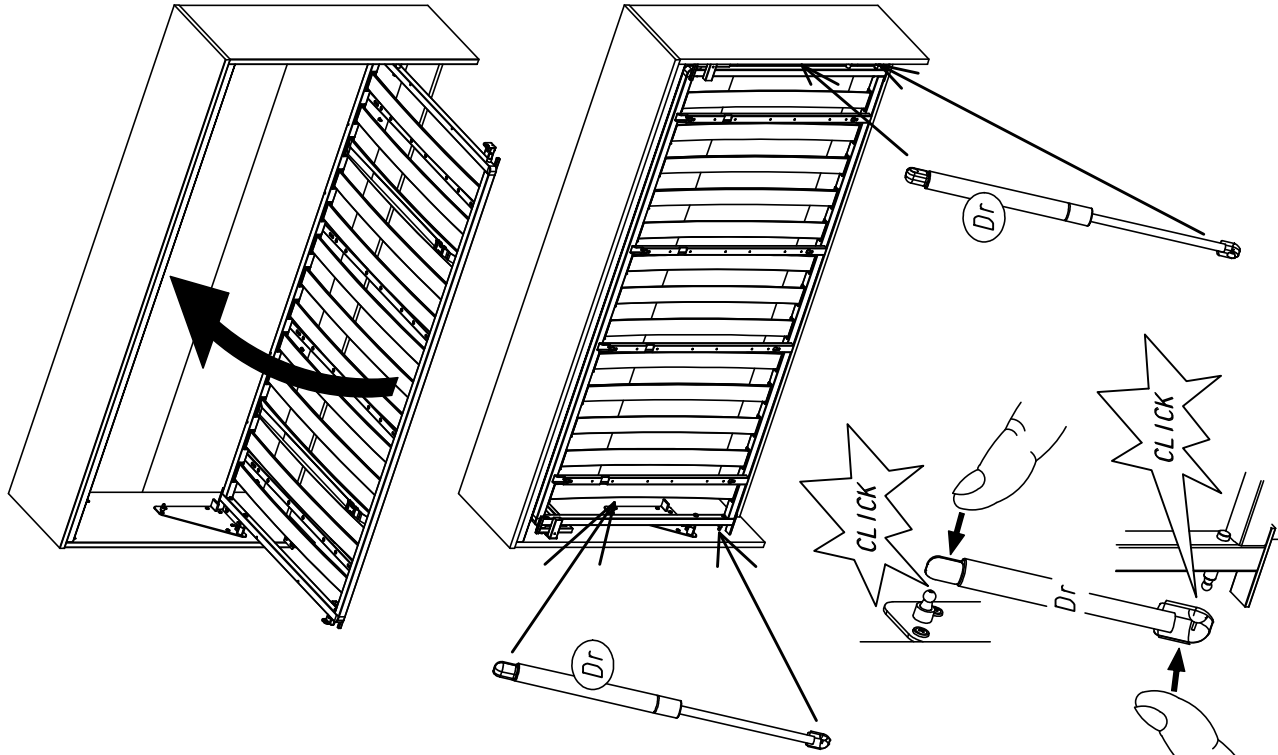

M2389

32.

30

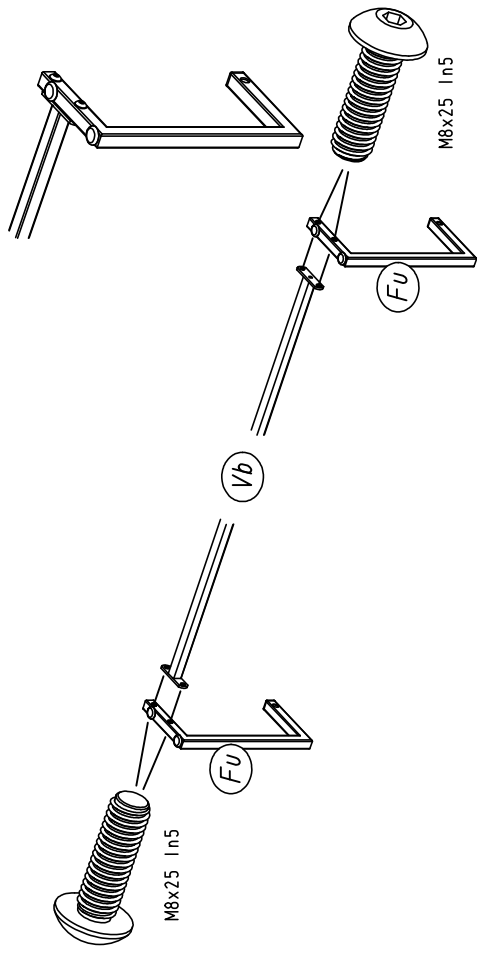

31

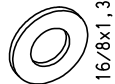

2x

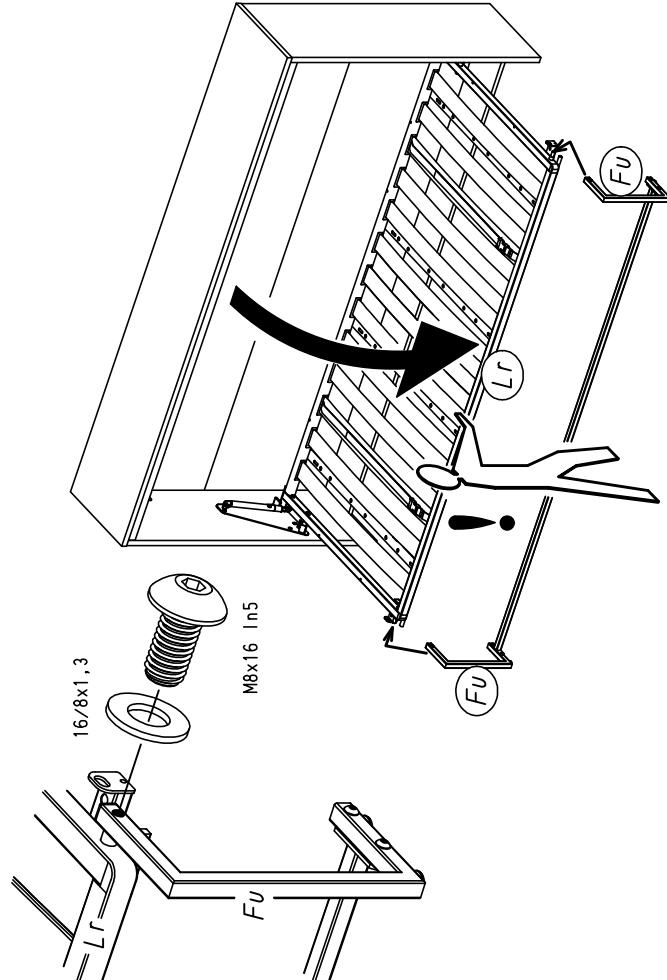
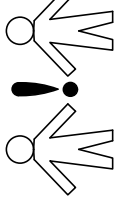
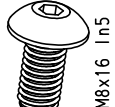

M2389

32

2X

581

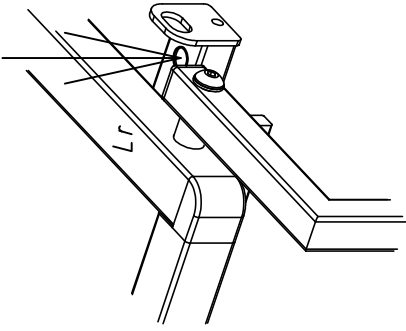
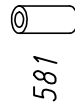
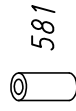
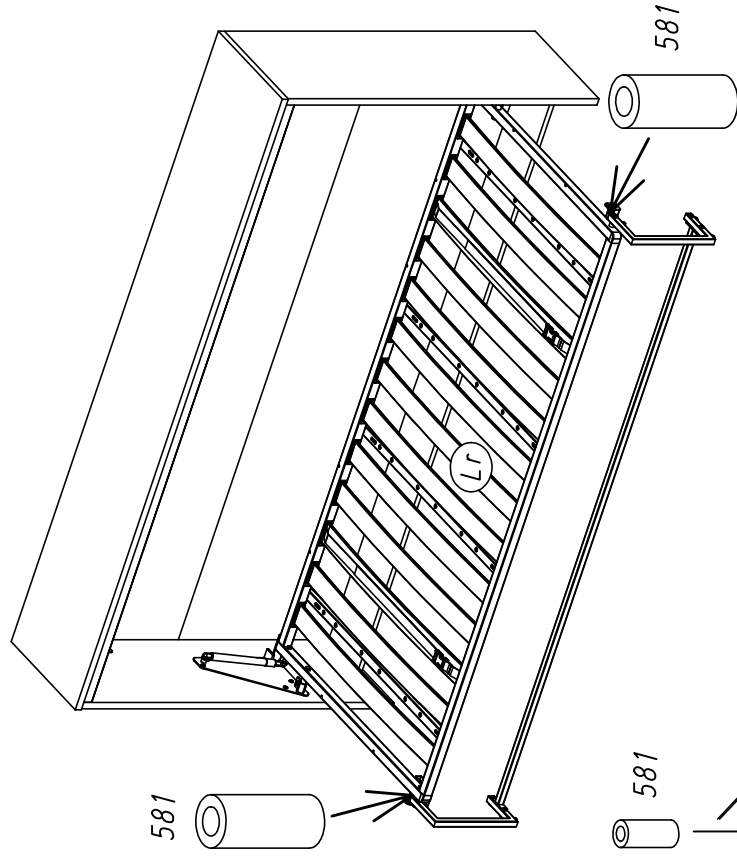
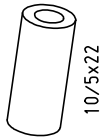

33

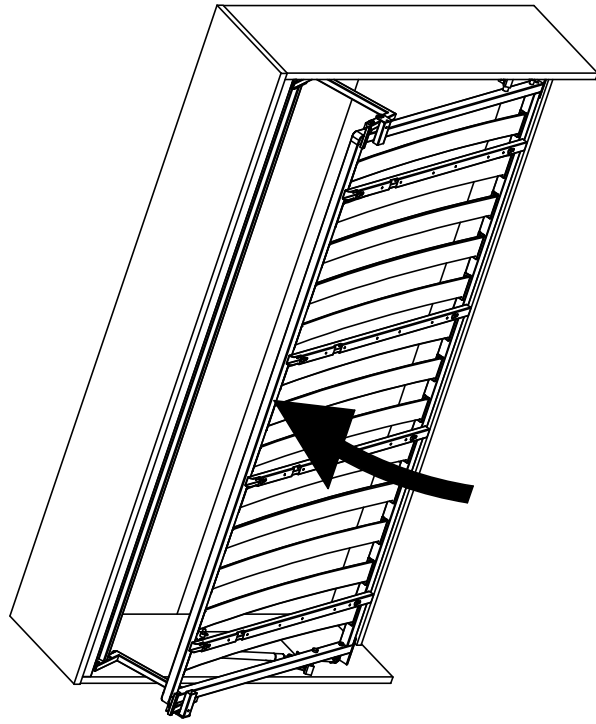

34

5X

167

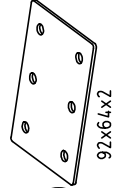

10X

26

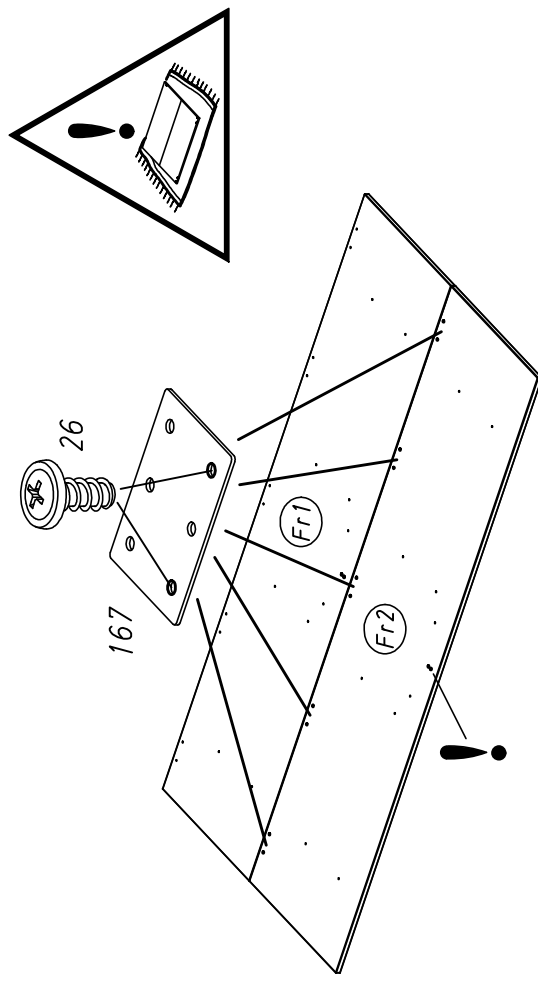

35.

10X 202
4,5x16

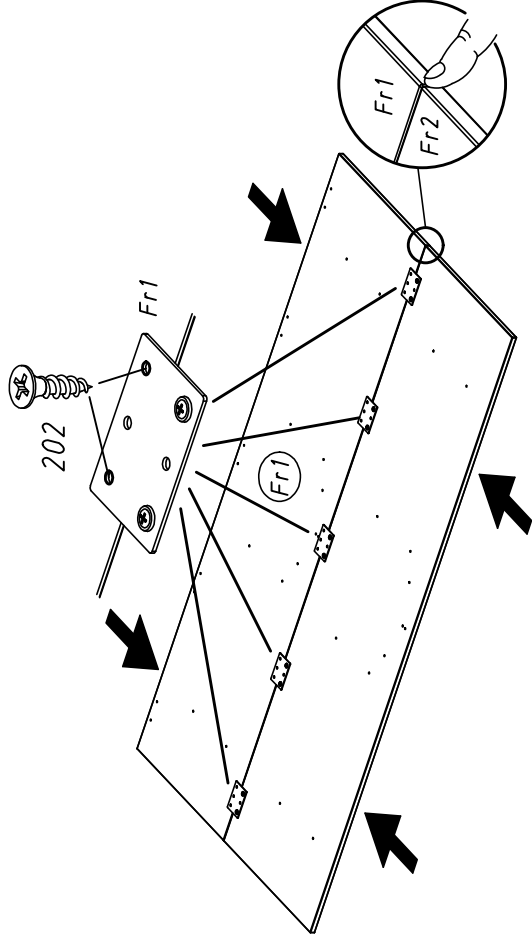

35

36.

8X 26
6,3x14

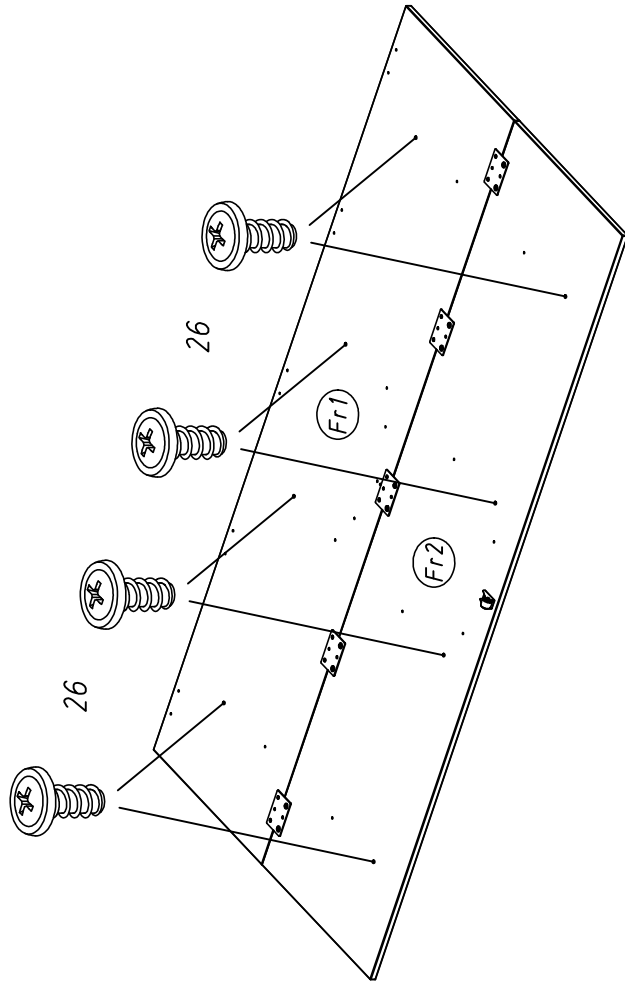

37

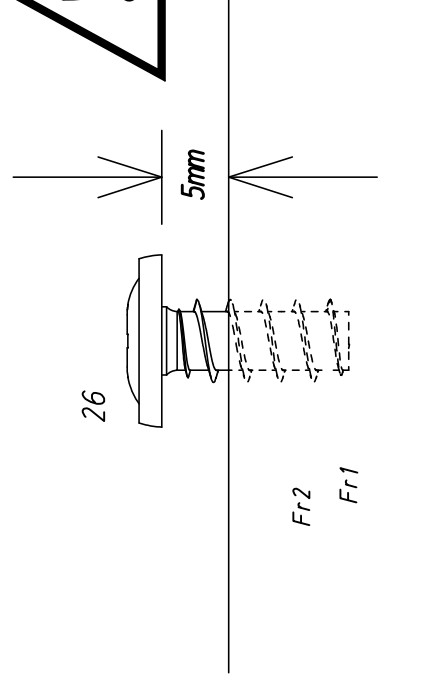
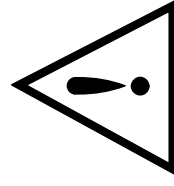

35.

10X 202
4,5x16

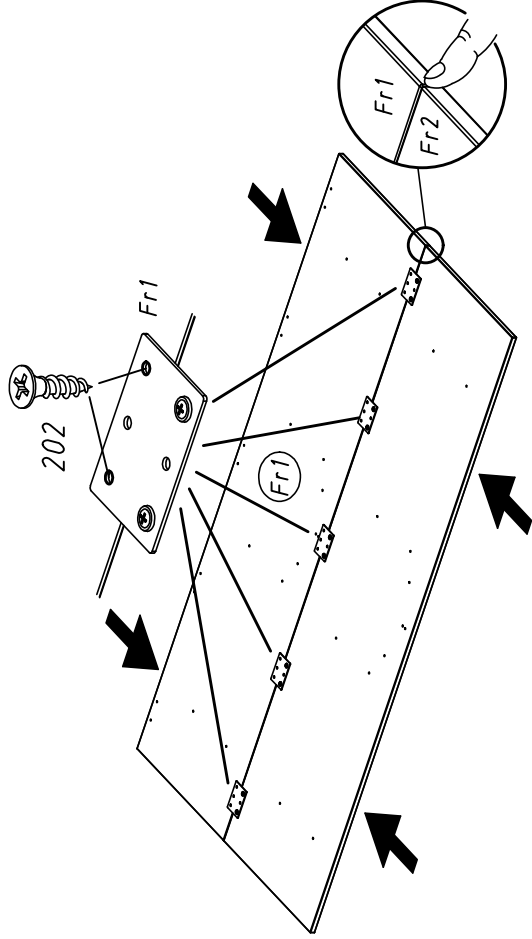

35

36.

8X 26
6,3x14

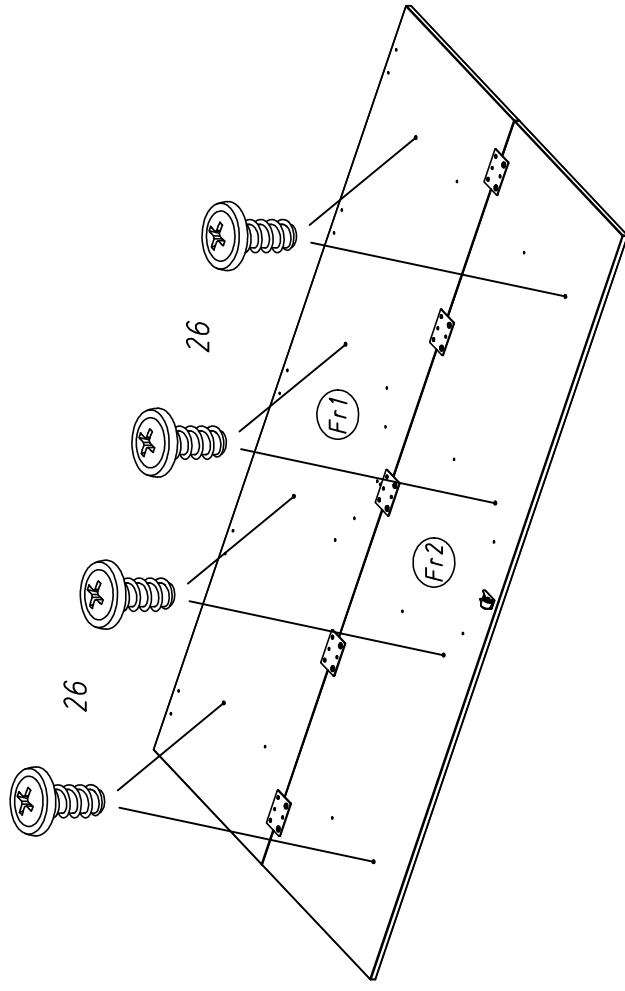
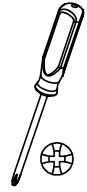

37

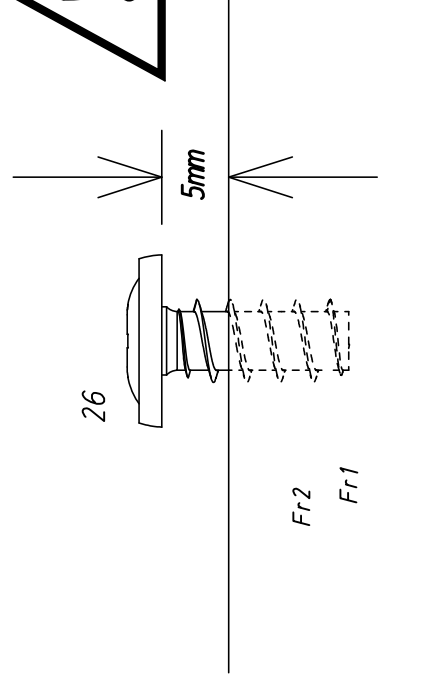
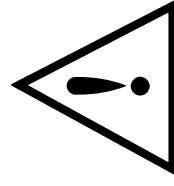

37.

38

2X 586

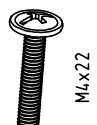

M4x22

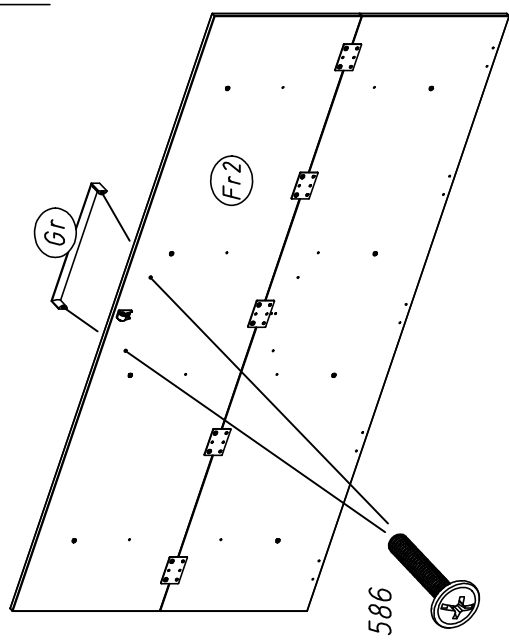
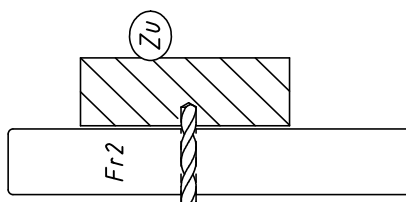
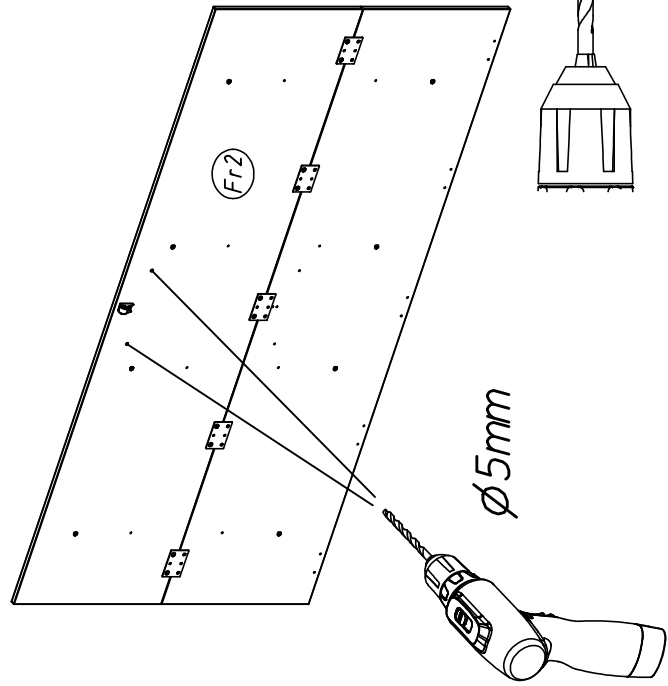
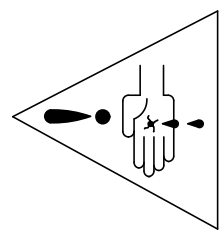
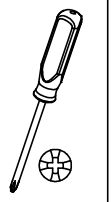
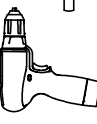
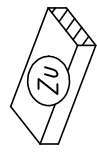

586

M2389

38.

39

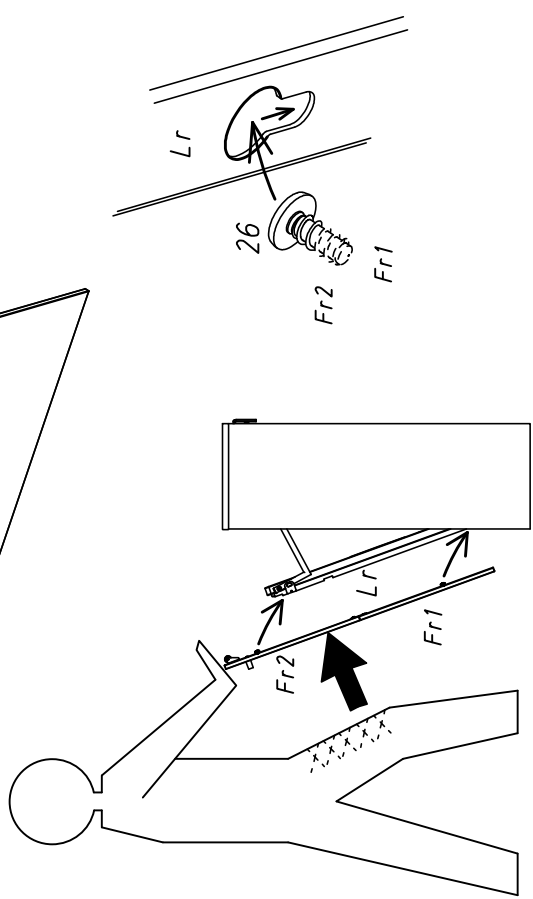
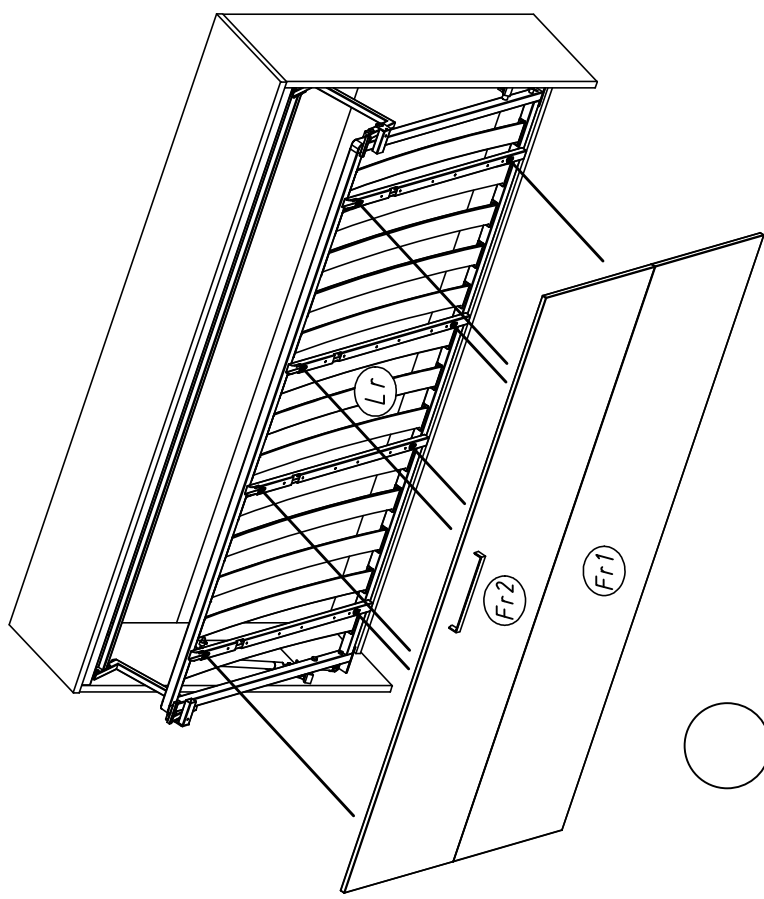
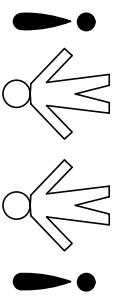

M2389

40.

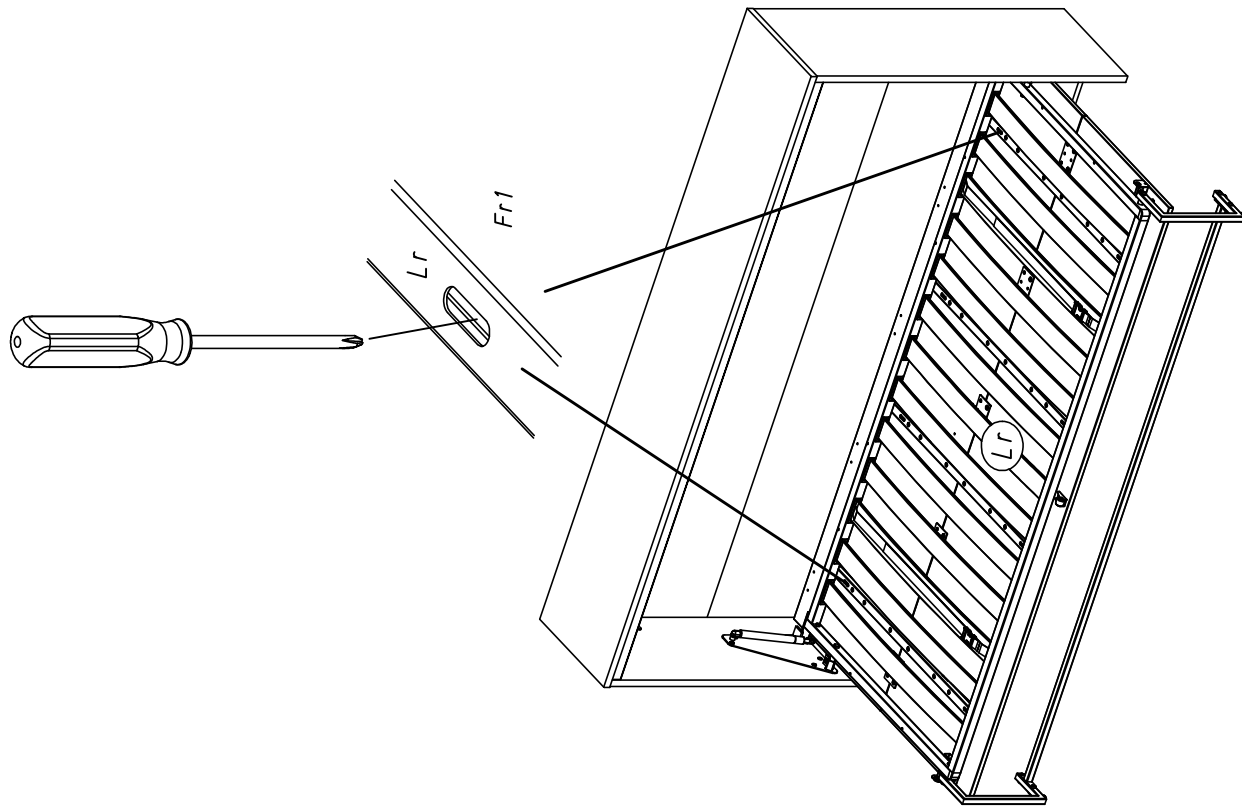

41

M2389

39.

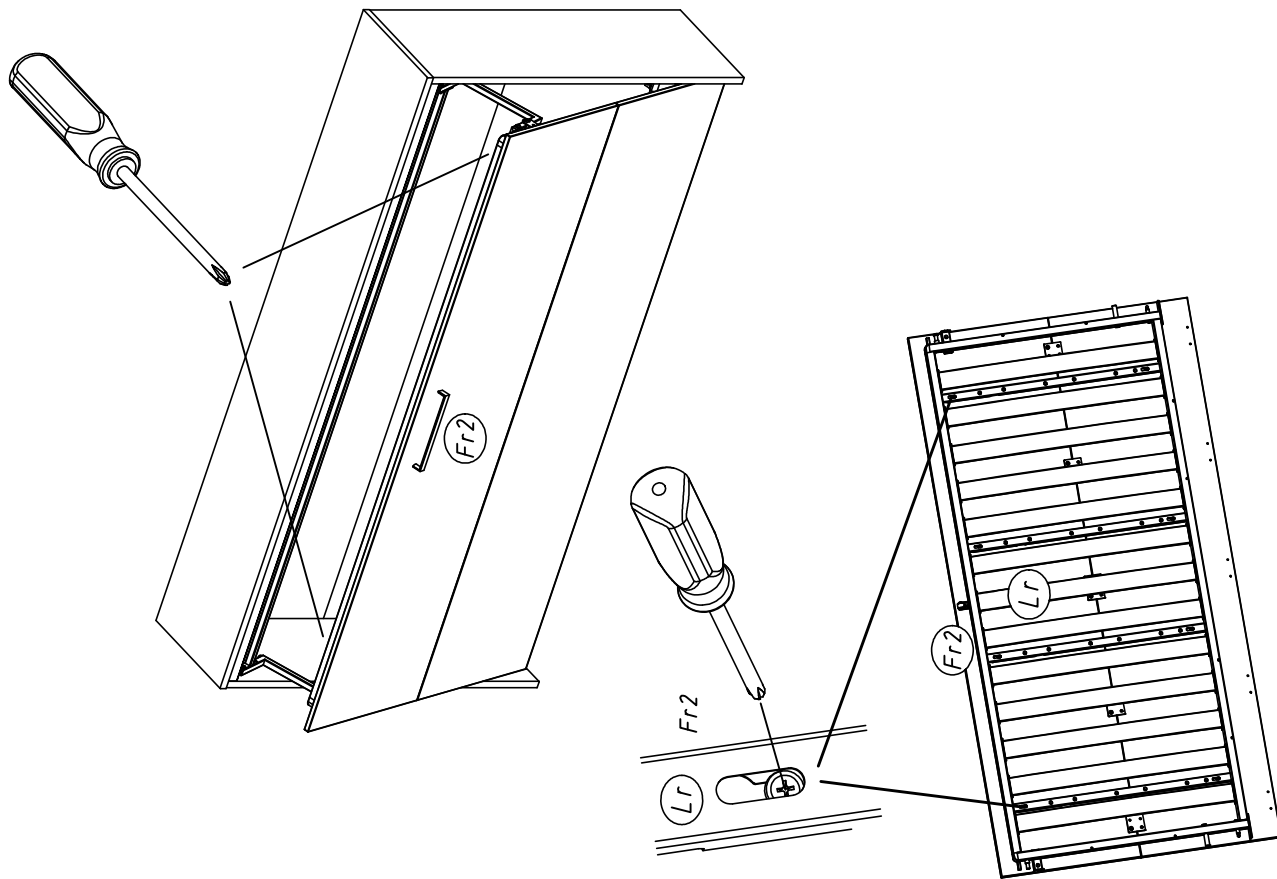

40

M2389

42.

43

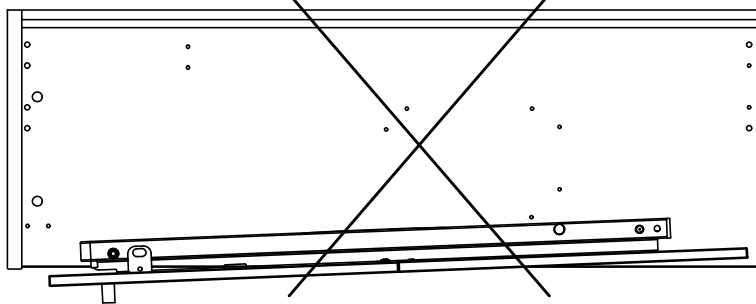
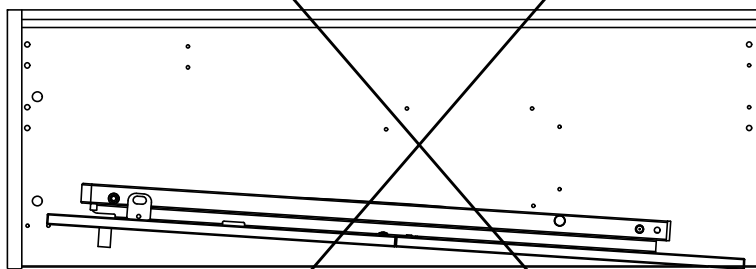
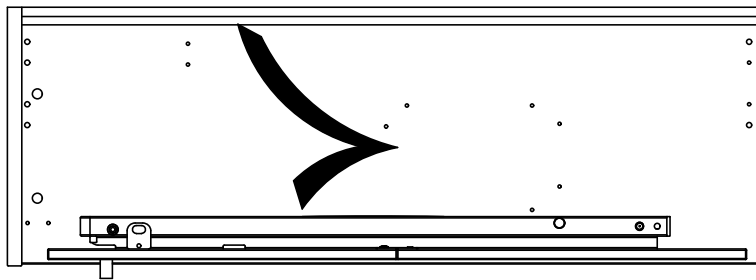
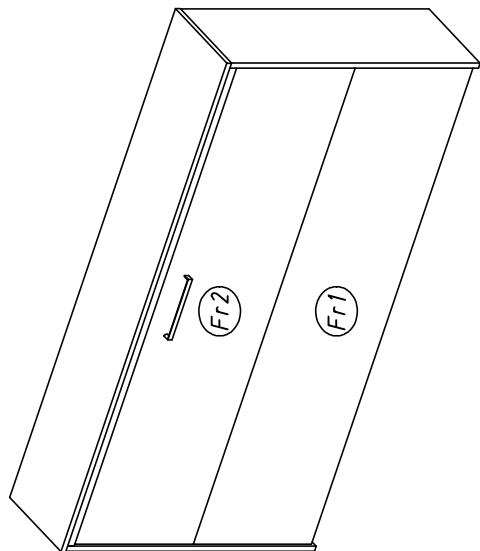

M2389

41.

42

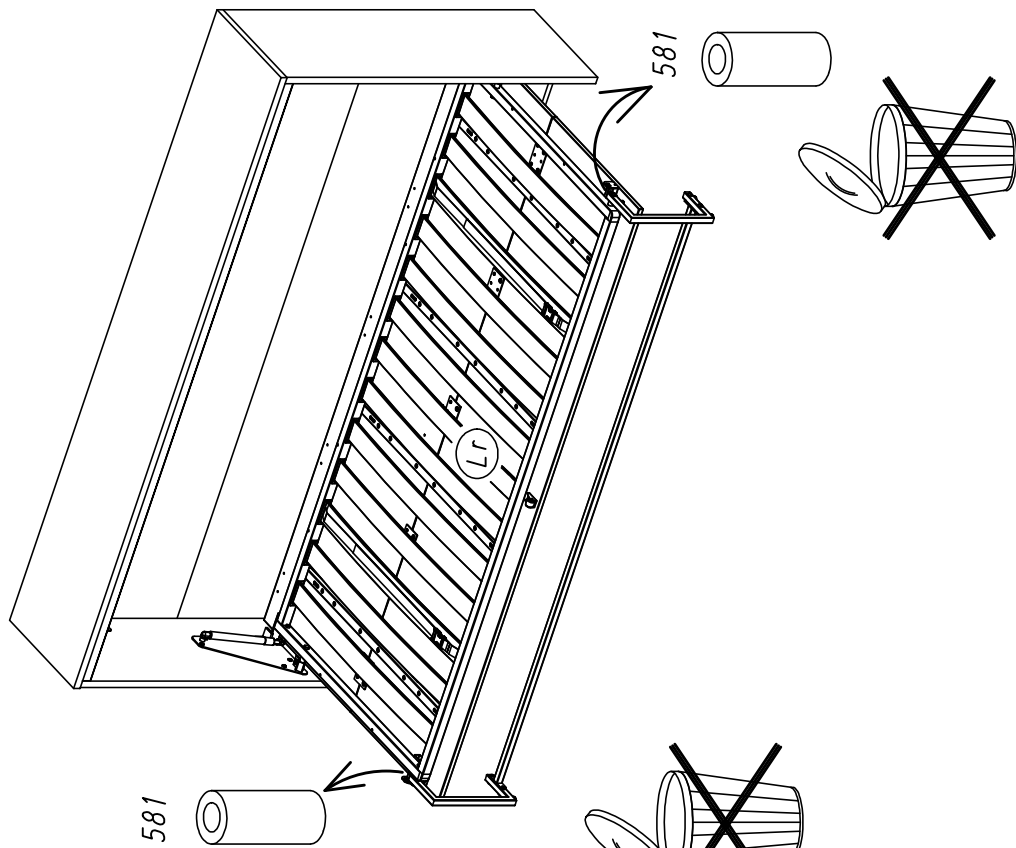

M2389

44

4X 201

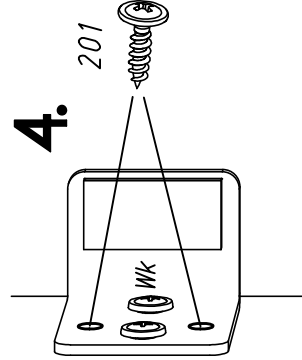
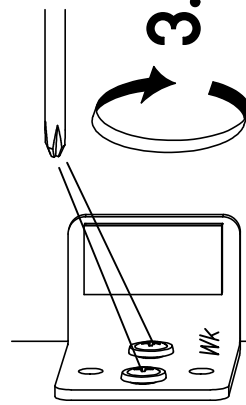
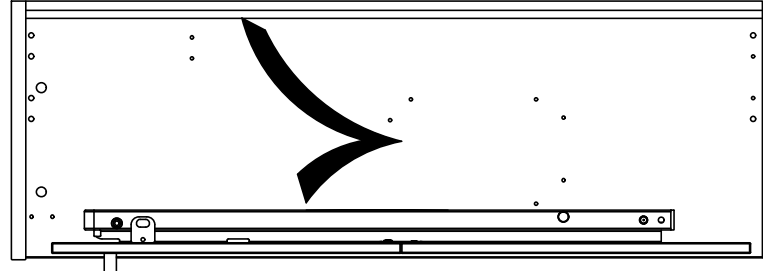
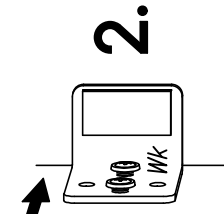
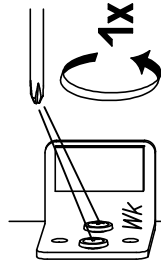
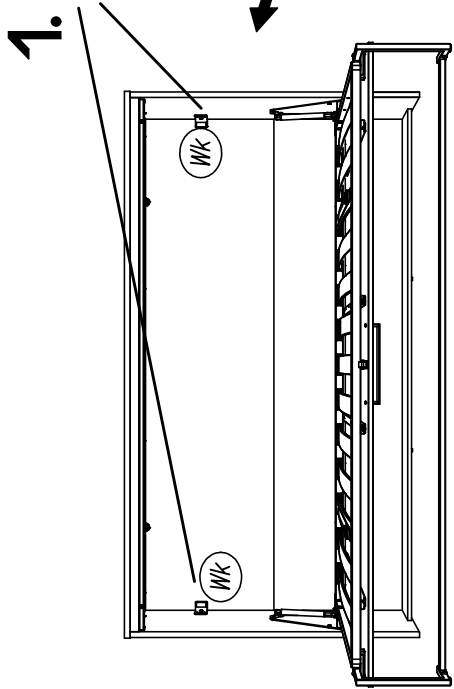

45

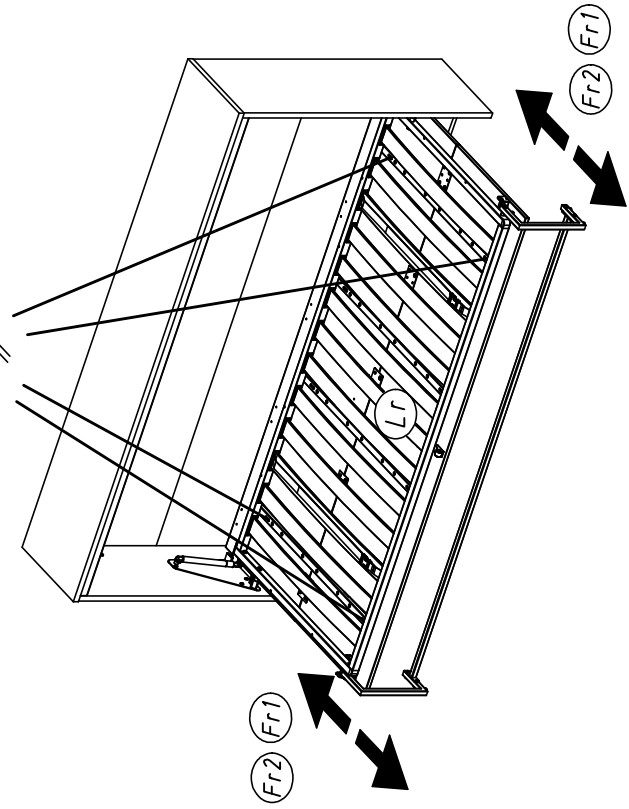
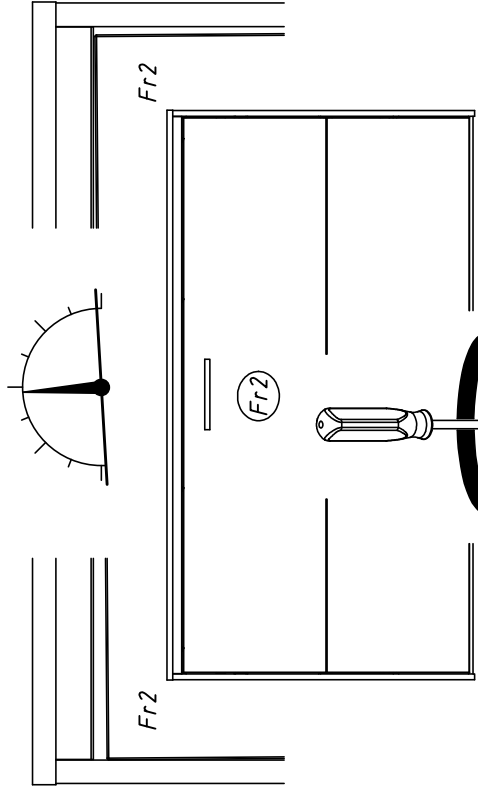

45.

46

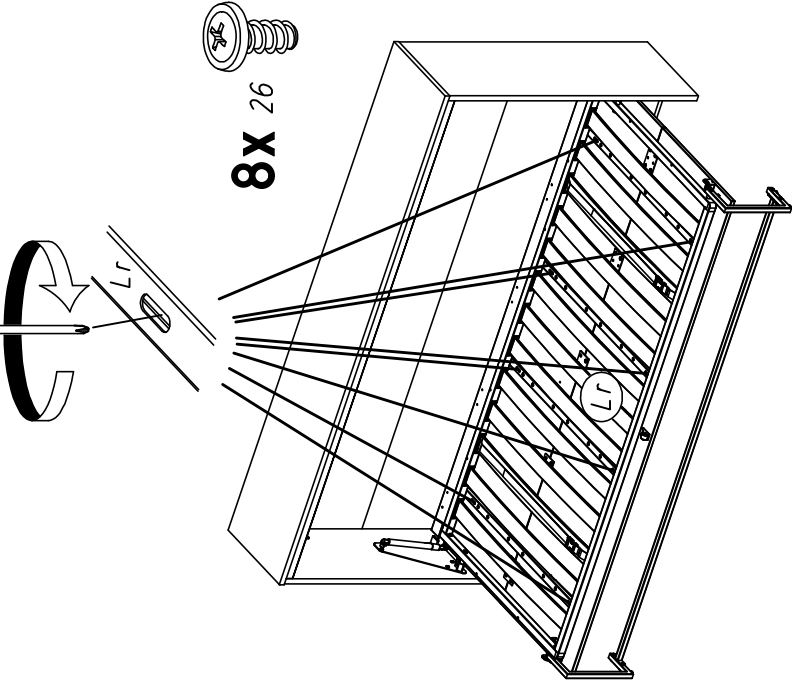
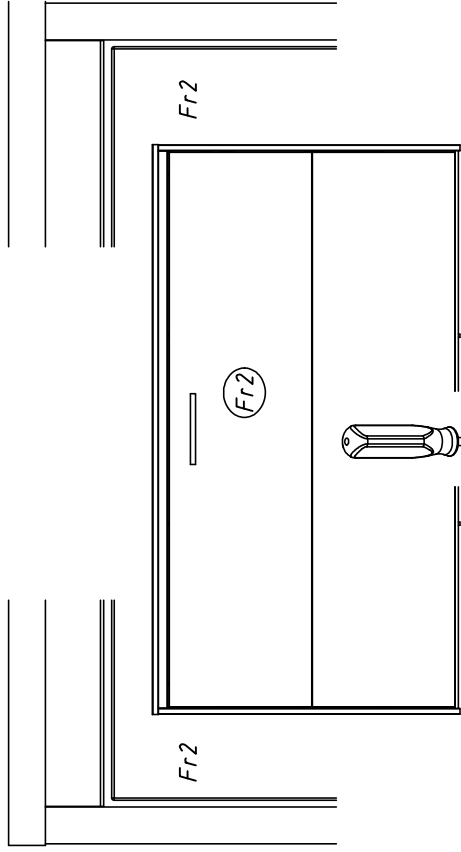

M2389

46.

47

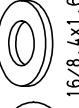

1009

16/8,4x1,6

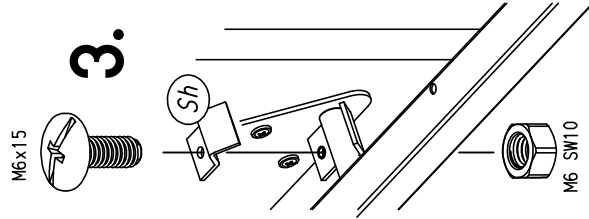
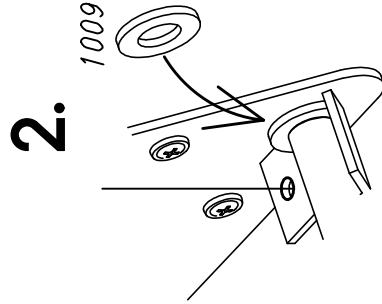
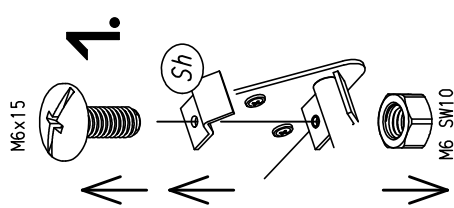
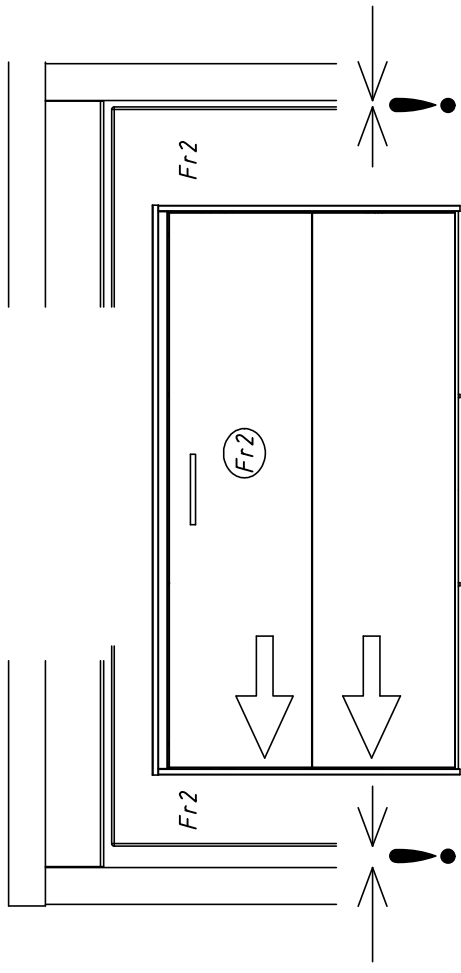

M2389

47

1x



16,8, 4x1,6

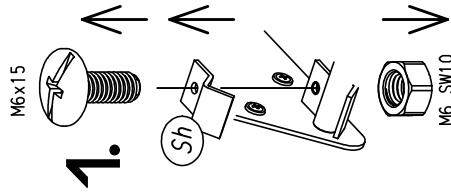
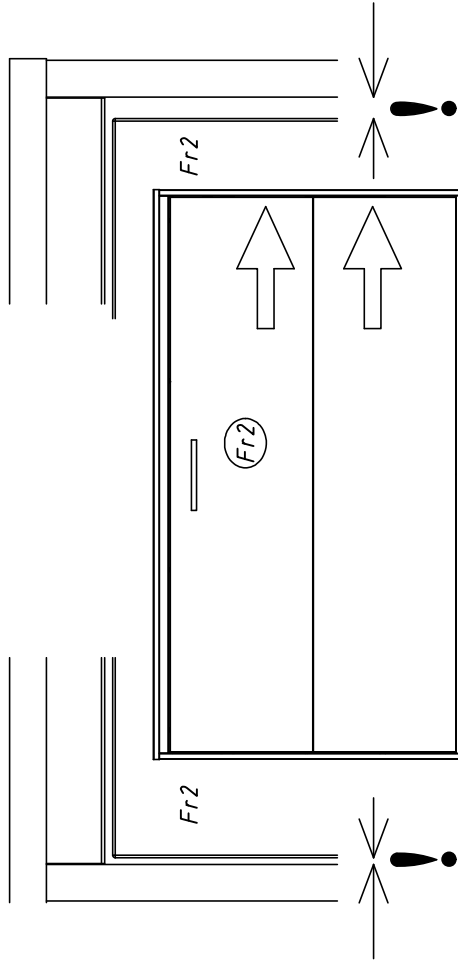

1.

2.

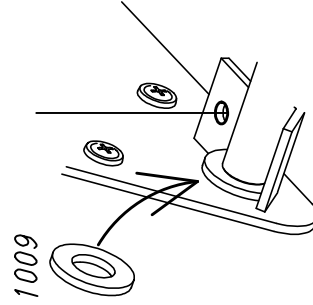

3.

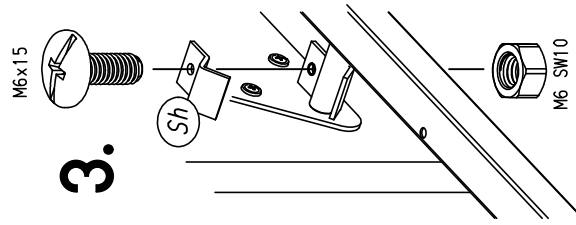

48

24x

201



4x15

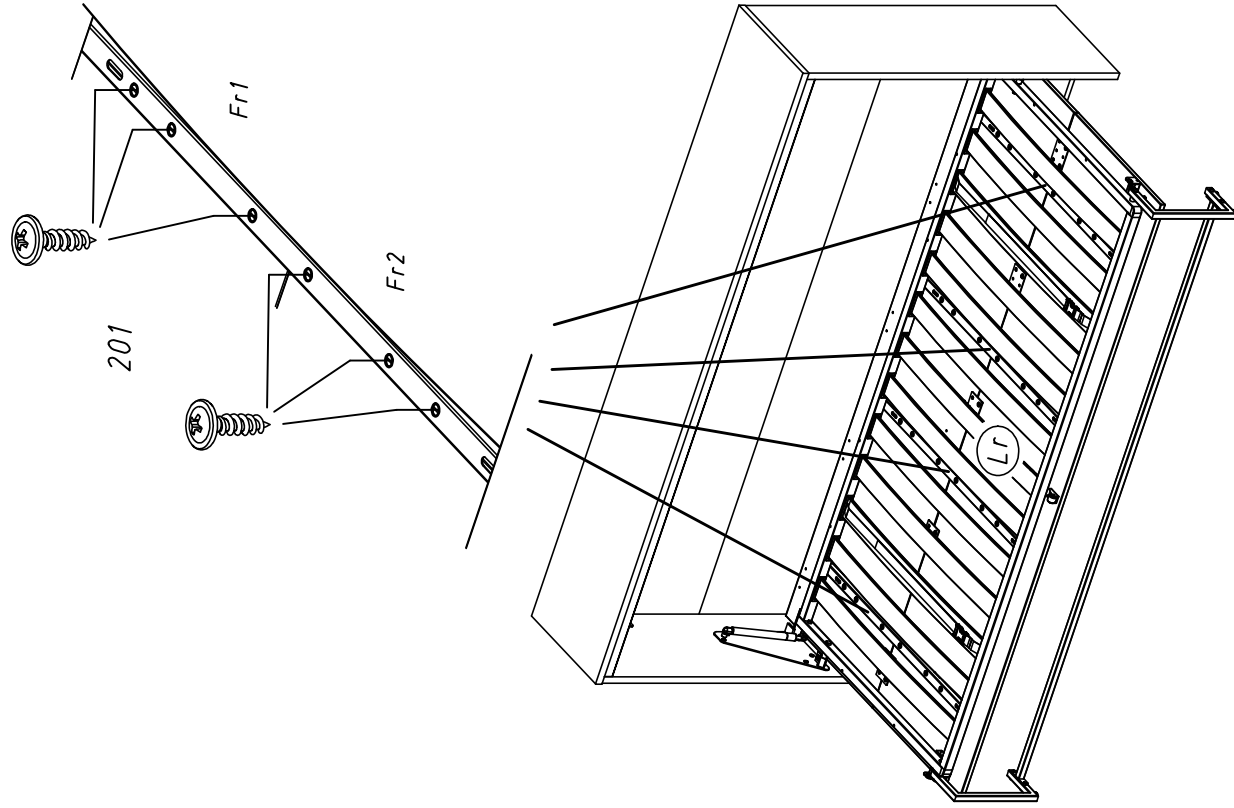

49.

49

2X 201

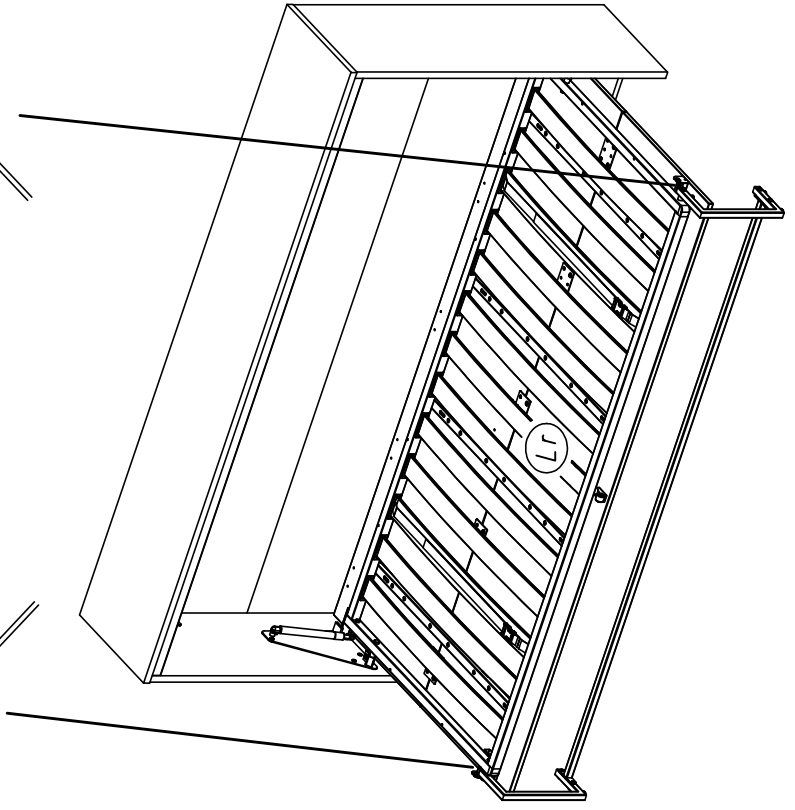
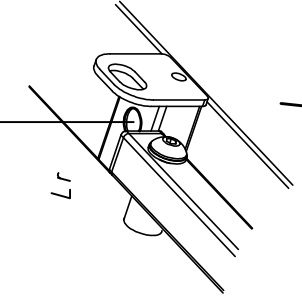
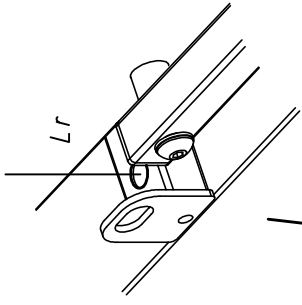
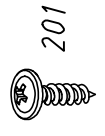

M2389

50.

50

4X 449

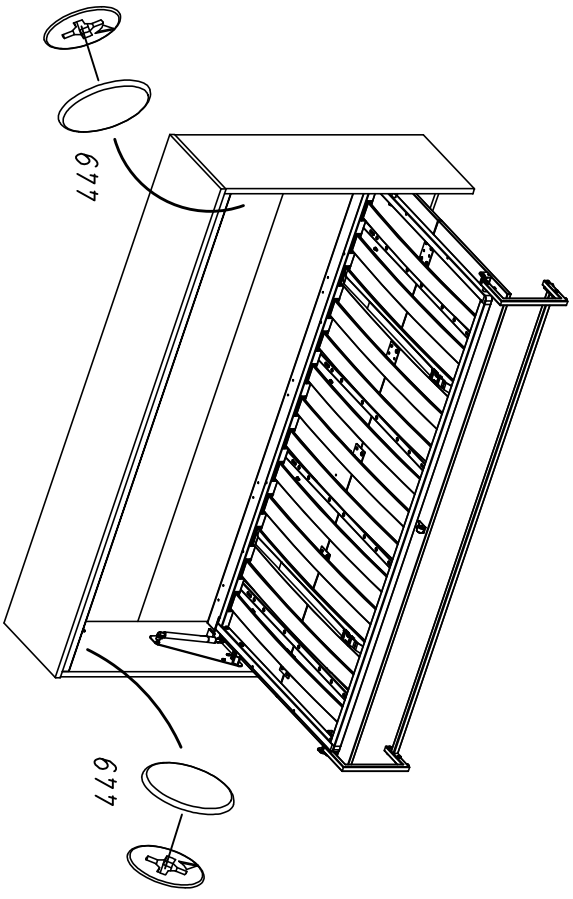
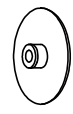

51

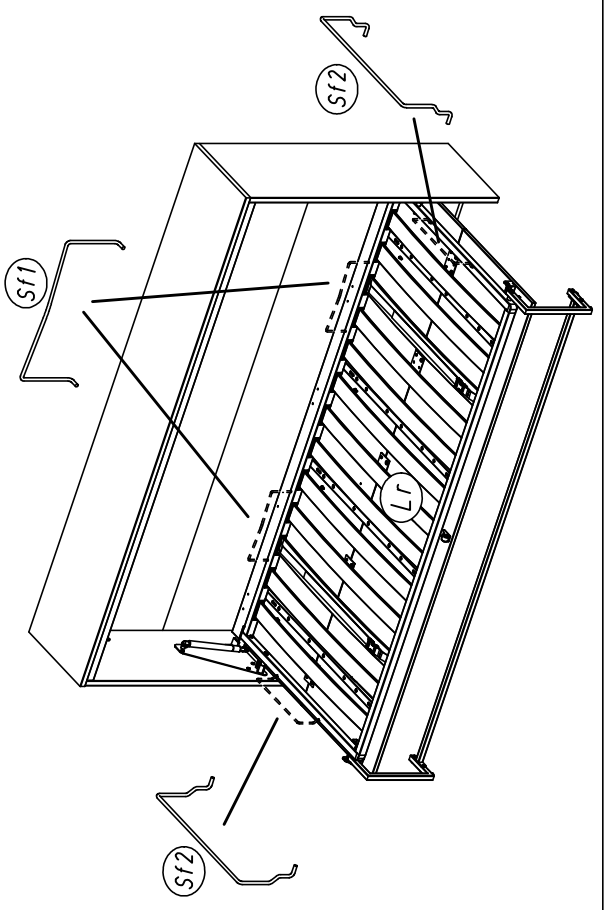

M2389

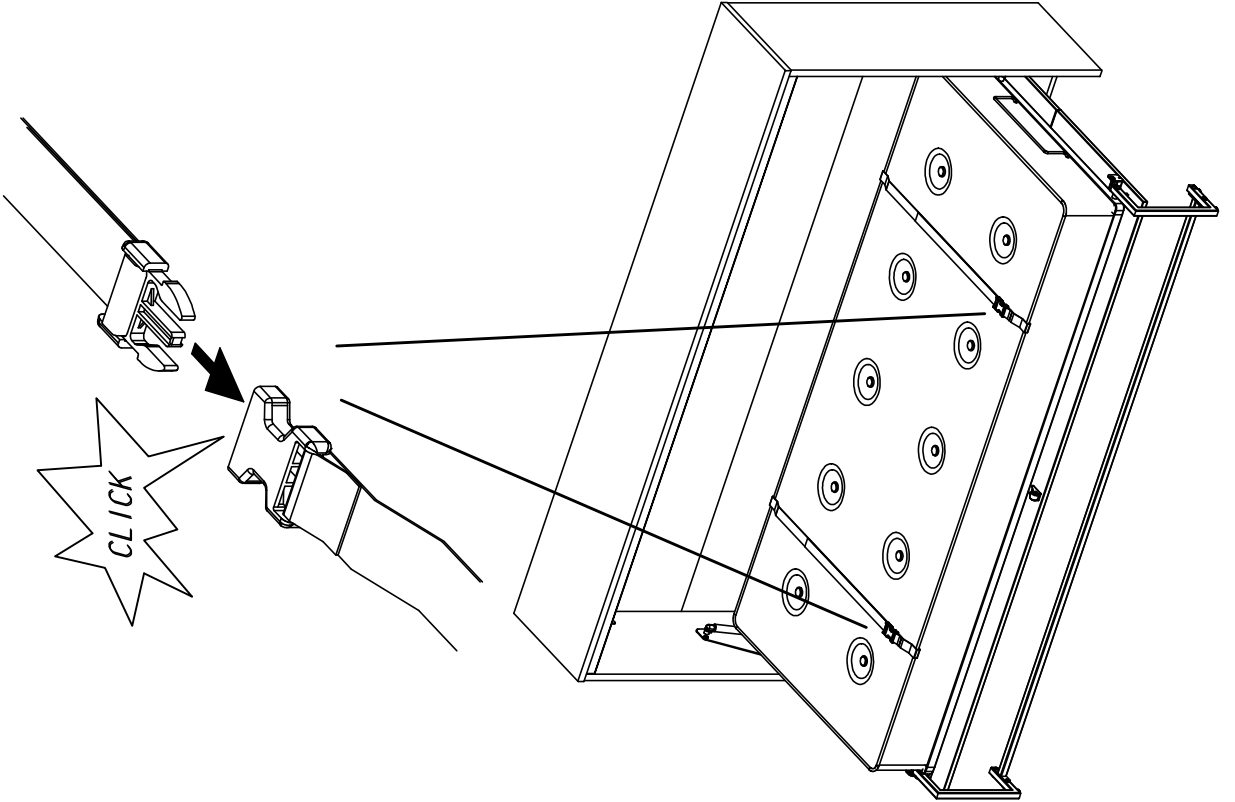
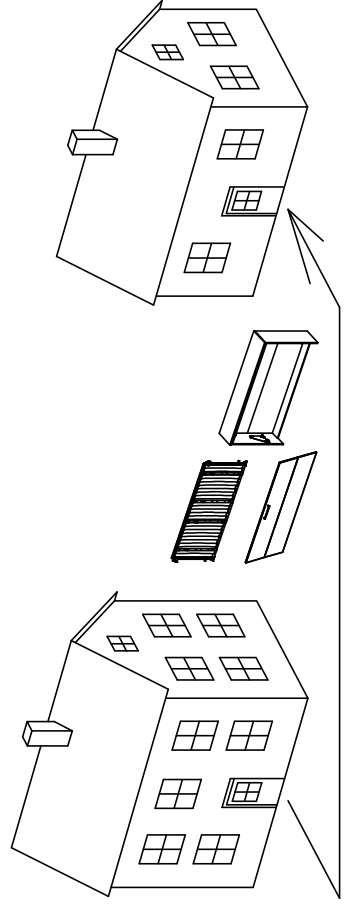
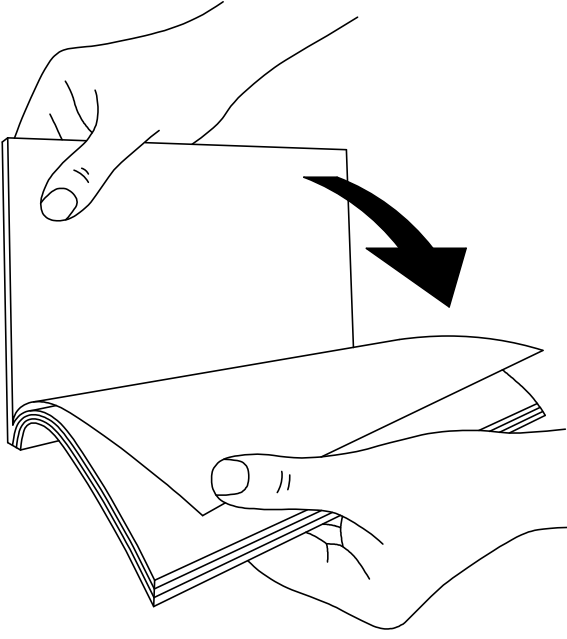

1

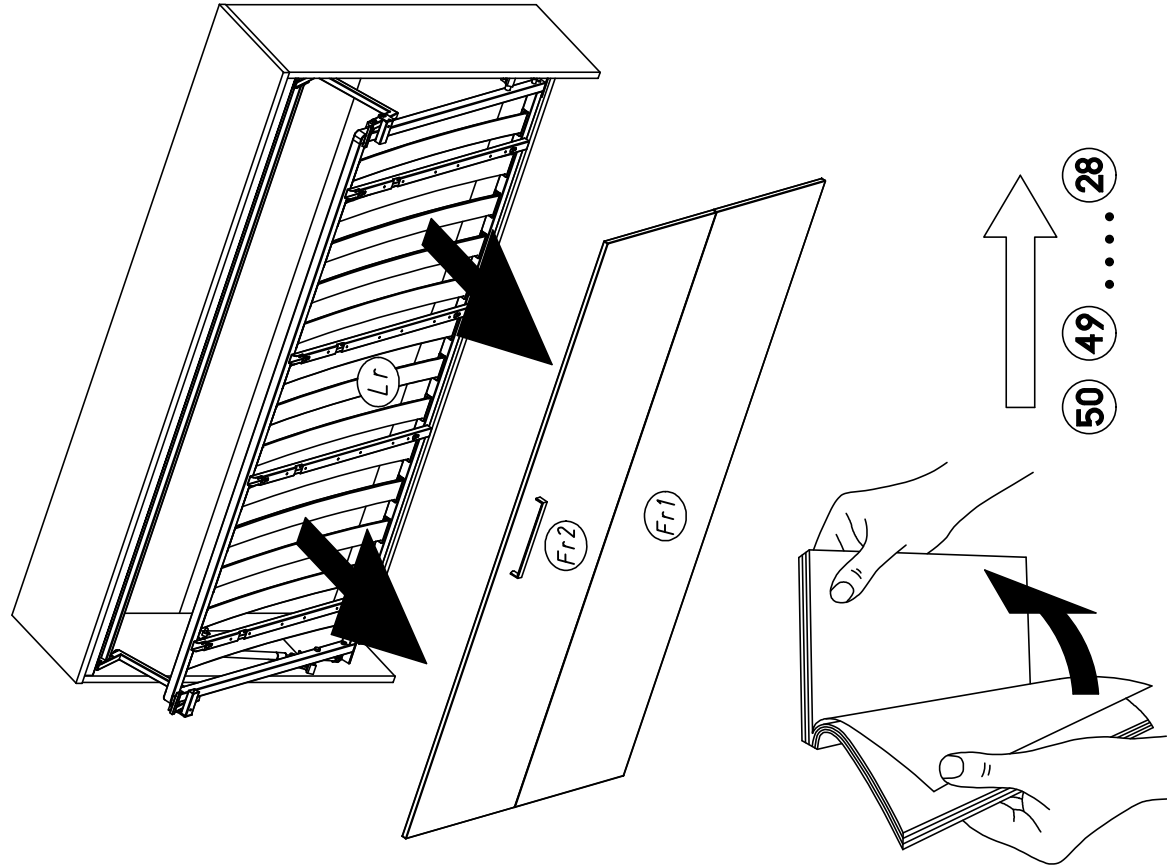

2

2x 581

